

OPERATOR'S MANUAL

ROTARY CUTTERS

RC1048

RC1060

RC1072

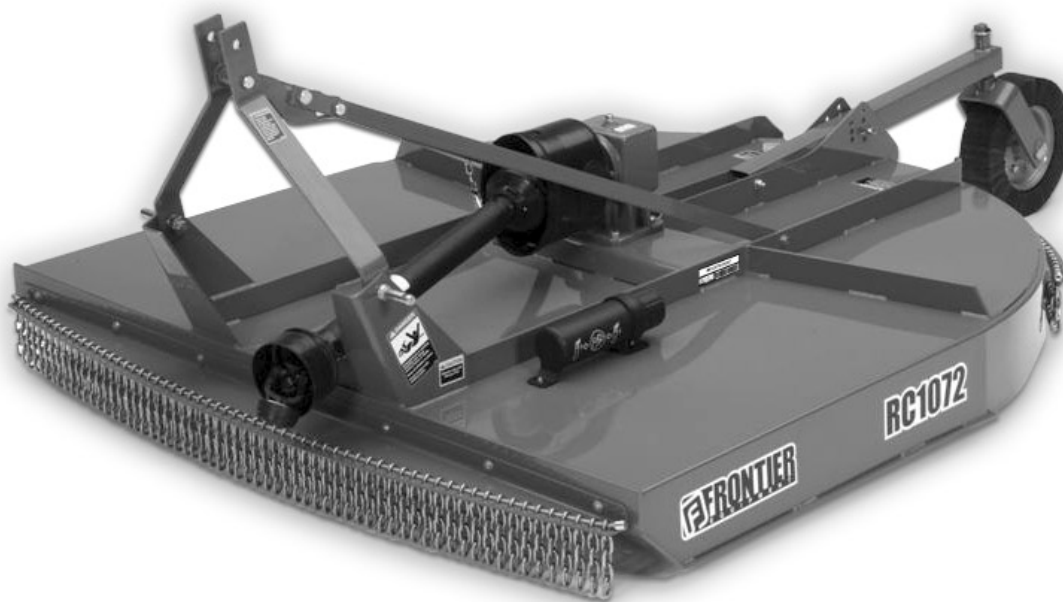

FRONTIER
EQUIPMENT™

DEALER PREPARATION CHECK LIST

Frontier 10 Series Rotary Cutter

THIS CHECKLIST IS TO REMAIN IN OWNER'S MANUAL

It is the responsibility of the dealer to complete the procedures listed below, then review this checklist with the customer upon the delivery or the sale of this implement.

- 1. Implement is completely assembled.
- 2. Gearbox filled with oil and checked for possible leaks. (See page 29)
- 3. All fittings lubricated. (See page 20 - 21)
- 4. All shields in place and in good condition.
- 5. All fasteners torqued to specifications in Torque Chart. (See page 32)
- 6. Check PTO driveline. Make sure it is the correct length to operate rotary cutter with intended tractor. (See page 16)
- 7. Check front of input gearbox shaft and make sure that snap ring is properly installed (PTO shaft shear pin only).
- 8. Check shear/retaining bolt for proper grade and installation. (See page 23, 24 and 37)
- 9. All decals in place and readable. (See page 8)
- 10. Overall condition good (i.e. paint, welds)
- 11. Operator's manual has been given to owner and the owner has been instructed on the safe and proper use of the rotary cutter.

Dealer's Signature _____

Purchaser's Signature _____

TO THE DEALER:

Assembly and proper installation of this product is the responsibility of the Frontier dealer. Read manual instructions and safety rules. Make sure all items on the Preparation Check List in the Operator's Manual are completed before releasing equipment to the owner.

The dealer must complete the Product Registration form, located on the Frontier website. Failure to complete and return the form does not diminish customer's warranty rights.

TO THE OWNER:

Read this manual before operating your Frontier equipment. Keep this manual handy for ready reference. Require all operators to read this manual carefully and become acquainted with all adjustments and operating procedures before attempting to operate the equipment. Replacement manuals can be obtained from your selling dealer.

The equipment you have purchased has been carefully engineered and manufactured to provide dependable and satisfactory use. Like all mechanical products, it will require cleaning and upkeep. Lubricate the unit as specified. Please observe all safety information in this manual and safety decals on the equipment.

For service, your authorized Frontier dealer has trained mechanics, genuine Frontier service parts, and the necessary tools and equipment to handle all of your service needs.

Use only genuine Frontier service parts. Substitute parts will void the warranty and may not meet standards required for safe and satisfactory operation. Record the model number and serial number of your equipment in the warranty page of this manual. (See page 43)

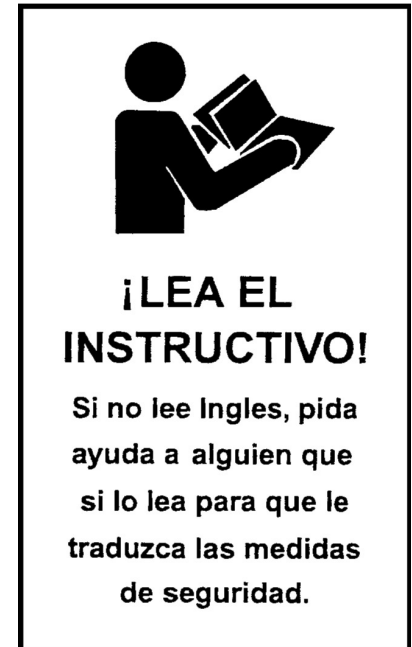

Throughout this manual, the term **IMPORTANT** is used to indicate that failure to observe procedures can cause damage to equipment. The terms **CAUTION**, **WARNING** and **DANGER** are used in conjunction with the Safety-Alert Symbol, (a triangle with an exclamation mark), to indicate the degree of hazard for items of personal safety.

 **This Safety-Alert Symbol indicates a hazard and means ATTENTION! BECOME ALERT! YOUR SAFETY IS INVOLVED!**

 **DANGER**

Indicates an imminently hazardous situation that, if not avoided, will result in death or serious injury.

 **WARNING**

Indicates a potentially hazardous situation that, if not avoided, could result in death or serious injury, and includes hazards that are exposed when guards are removed.

 **CAUTION**

Indicates a potentially hazardous situation that, if not avoided, may result in minor or moderate injury.

IMPORTANT Indicates that failure to observe can cause damage to equipment.

NOTE Indicates helpful information.

TABLE OF CONTENTS

Introduction.....	4
Safety	5-9
Description	10-11
Preparation.....	12-13
Attaching	14-16
Detaching	16-17
Operation.....	17-19
Lubrication & Maintenance.....	20-21
Service	22-26
Storage	26
Assembly & Setup.....	27-31
Bolt Torque Chart	32
Troubleshooting.....	33
Parts	34-42
Replacements Parts / Product Warranty.....	43

All information, illustrations and specifications in this manual are based on the latest information available at the time of publication. The right is reserved to make changes at any time without notice.

General Information

The purpose of this manual is to assist you in operating and maintaining your rotary cutter for years of service. Read it carefully. The information and instructions in this manual have been compiled from extensive field experience and engineering data. Some information may be general in nature due to unknown and varying operating conditions. However, through experience and these instructions, you should be able to develop procedures suitable to your particular situation.

The illustrations and data used in this manual were current at the time of printing, but due to possible inline production changes, your machine may vary slightly in detail. We reserve the right to redesign and change the machines as may be necessary without notification.

 **WARNING: Some illustrations in this manual show the rotary cutter with safety shields removed to provide a better view. The rotary cutter should never be operated with any safety shielding removed.**

Throughout this manual, references are made to right and left direction. These are determined by standing behind the equipment facing the direction of forward travel. Blade rotation is counter-clockwise as viewed from the top of the mower.

SAFETY RULES



ATTENTION! BECOME ALERT! YOUR SAFETY IS INVOLVED!



Safety is a primary concern in the design and manufacture of our products. Unfortunately, our efforts to provide safe equipment can be wiped out by an operator's single careless act.

In addition to the design and configuration of equipment, hazard control and accident prevention are dependent upon the awareness, concern, judgment, and proper training of personnel involved in the operation, transport, maintenance and storage of equipment.

It has been said "The best safety device is an informed, careful operator." We ask you to be that kind of operator.

• Training

Safety instructions are important! Read all attachment and power unit manuals; follow all safety rules and safety decal information. (Replacement manuals and safety decals are available from your dealer.) Failure to follow instructions or safety rules can result in serious injury or death.

If you do not understand any part of this manual and need assistance, see your dealer.

Know your controls and how to stop engine and attachment quickly in an emergency.

Operators must be instructed in and be capable of the safe operation of the equipment, its attachments, and all controls. Do not allow anyone to operate this equipment without proper instructions.

Never allow children or untrained persons to operate equipment.

• Preparation

Check that all hardware is properly installed. Always tighten to torque chart specifications unless instructed otherwise in this manual.

Always wear relatively tight and belted clothing to avoid getting caught in moving parts. Wear sturdy, rough-soled work shoes and protective equipment for eyes, hair, hands, hearing, and head; and respirator or filter mask where appropriate.

Make sure attachment is properly secured, adjusted, and in good operating condition.

Make sure collar slides freely and is seated firmly in tractor PTO spline groove.

Before putting equipment into service, check and

adjust driveline length as instructed in Operator's Manual. Driveline must not bottom out or pull apart throughout the full range of the tractor hitch. Do not operate until driveline length is correct.

Make sure driveline shield safety chain is attached as shown in this manual. Replace if damaged or broken. Check that driveline guards rotate freely on driveline before putting equipment into service.

Before starting power unit, check all equipment driveline guards for damage. Replace any damaged guards. Make sure all guards rotate freely on all drivelines. If guards do not rotate freely on drivelines, repair and replace bearings before putting equipment into service.

Inspect chain or rubber deflectors before each use. Replace if damaged.

Remove accumulated debris from this equipment, power unit, and engine to avoid fire hazard.

Power unit must be equipped with ROPS or ROPS cab and seat belt. Keep seat belt securely fastened. Falling off power unit can result in death from being run over or crushed. Keep foldable ROPS system in "locked up" position at all times.

A minimum 20% of tractor and equipment weight must be on the tractor front wheels when attachments are in transport position. Without this weight, tractor could tip over, causing personal injury or death. The weight may be attained with a loader, front wheel weights, ballast in tires or front tractor weights. Weigh the tractor and equipment. Do not estimate.

(Safety Rules continued on next page)

SAFETY RULES



ATTENTION! BECOME ALERT! YOUR SAFETY IS INVOLVED!



(Safety Rules continued from previous page)

Make sure all safety decals are installed. Replace if damaged. (See Safety Decals section for location.)

Make sure shields and deflectors are properly installed and in good condition. Replace if damaged.

Inspect and clear area of stones, branches, or other hard objects that might be thrown, causing injury or damage.

• **Transportation**

Power unit must be equipped with ROPS or ROPS cab and seat belt. Keep seat belt securely fastened. Falling off power unit can result in death from being run over or crushed. Keep foldable ROPS system in “locked up” position at all times.

A minimum 20% of tractor and equipment weight must be on the tractor front wheels when attachments are in transport position. Without this weight, tractor could tip over, causing personal injury or death. The weight may be attained with a loader, front wheel weights, ballast in tires or front tractor weights. Weigh the tractor and equipment. Do not estimate.

Always comply with all state and local lighting and marking requirements.

Never allow riders on power unit or attachment.

Do not operate PTO during transport.

Watch for hidden hazards on the terrain.

Do not operate or transport on steep slopes.

Do not operate or transport equipment while under the influence of alcohol or drugs.

• **Operation**

Do not allow bystanders in the area when operating, attaching, removing, assembling, or servicing equipment.

Never direct discharge toward people, animals, or property.

Use both front and rear deflectors to reduce the possibility of object being thrown.

These mowers are intended for agricultural applications only. Do not operator within 300 feet of bystanders or public roads or highways.

Do not operate or transport equipment while under the influence of alcohol or drugs.

Keep hands, feet, hair, and clothing away from equipment while engine is running. Stay clear of all moving parts.

Operate only in daylight or good artificial light. Always comply with all state and local lighting and marking requirements.

Never allow riders on power unit or attachment.

Power unit must be equipped with ROPS or ROPS cab and seat belt. Keep seat belt securely fastened. Falling off power unit can result in death from being run over or crushed. Keep foldable ROPS system in “locked up” position at all times.

Always sit in power unit seat when operating controls or starting engine. Securely fasten seat belt, place transmission in neutral, engage brake, and ensure all other controls are disengaged before starting power unit engine.

Operate tractor PTO at 540 RPM. Do not exceed.

Do not operate PTO during transport.

Look down and to the rear and make sure area is clear before operating in reverse.

Do not operate or transport on steep slopes.

Do not stop, start, or change directions suddenly on slopes.

Use extreme care and reduce ground speed on slopes and rough terrain.

Watch for hidden hazards on the terrain during operation.

SAFETY RULES



ATTENTION! BECOME ALERT! YOUR SAFETY IS INVOLVED!



Stop power unit and equipment immediately upon striking an obstruction. Turn off engine, remove key, inspect, and repair any damage before resuming operation.

Leak down or failure of mechanical or hydraulic system can cause equipment to drop.

• Maintenance

Before dismounting power unit or performing any service or maintenance, follow these steps: disengage power to equipment, lower the 3-point hitch and all raised components to the ground, set parking brake, stop engine, remove key, and unfasten seat belt.

Before performing any service or maintenance, disconnect driveline from tractor PTO.

Before working underneath, carefully read Operator's Manual instructions, disconnect drive line, raise mower, securely block up all corners with jackstands, and check stability. Secure blocking prevents equipment from dropping due to hydraulic leak down, hydraulic system failures, or mechanical component failures.

Do not modify or alter or permit anyone else to modify or alter the equipment or any of its components in any way.

Always wear relatively tight and belted clothing to avoid getting caught in moving parts. Wear sturdy, rough-soled work shoes and protective equipment for eyes, hair, hands, hearing, and head; and respirator or filter mask where appropriate.

Make sure attachment is properly secured, adjusted, and in good operating condition.

Keep all persons away from operator control area while performing adjustments, service, or maintenance.

Never go underneath equipment (lowered to the ground or raised) unless it is properly blocked and secured. Never place any part of the body under neath equipment or between moveable parts even when the engine has been turned off. Hydraulic system

leak down, hydraulic system failures, mechanical failures, or movement of control levers can cause equipment to drop or rotate unexpectedly and cause severe injury or death. Follow Operator's Manual instructions for working underneath and blocking requirements or have work done by a qualified dealer.

Make certain all movement of equipment components has stopped before approaching for service.

Frequently check blades. They should be sharp, free of nicks and cracks, and securely fastened.

Do not handle blades with bare hands. Careless or improper handling may result in serious injury.

Your dealer can supply genuine replacement blades. Substitute blades may not meet original equipment specifications and may be dangerous.

Tighten all bolts, nuts, and screws to torque chart specifications. Check that all cotter pins are installed securely to ensure equipment is in a safe condition before putting unit into service.

Make sure all safety decals are installed. Replace if damaged. (See Safety Decals section for location.)

Make sure shields and deflectors are properly installed and in good condition. Replace if damaged.

• Storage

Block equipment securely for storage.

Keep children and bystanders away from storage area.

Follow manual instructions for storage.



SAFETY and INSTRUCTIONAL DECALS

ATTENTION! BECOME ALERT! YOUR SAFETY IS INVOLVED!



Replace Immediately if Damaged!

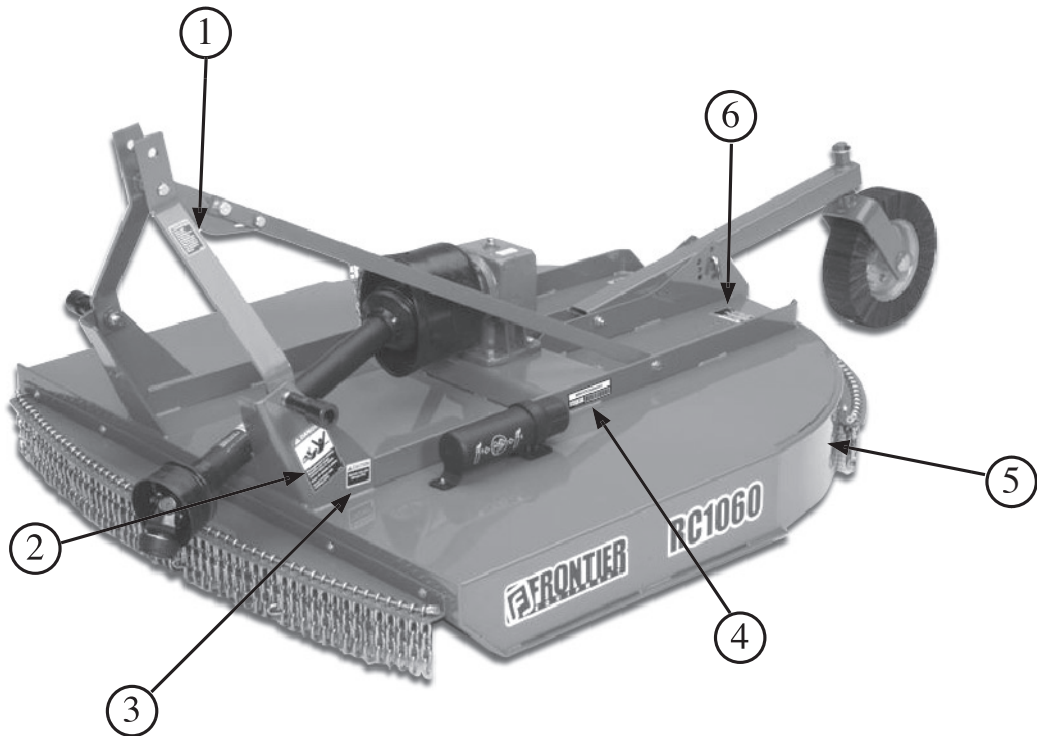

RC1060 WITH LAMINATED TAILWHEEL

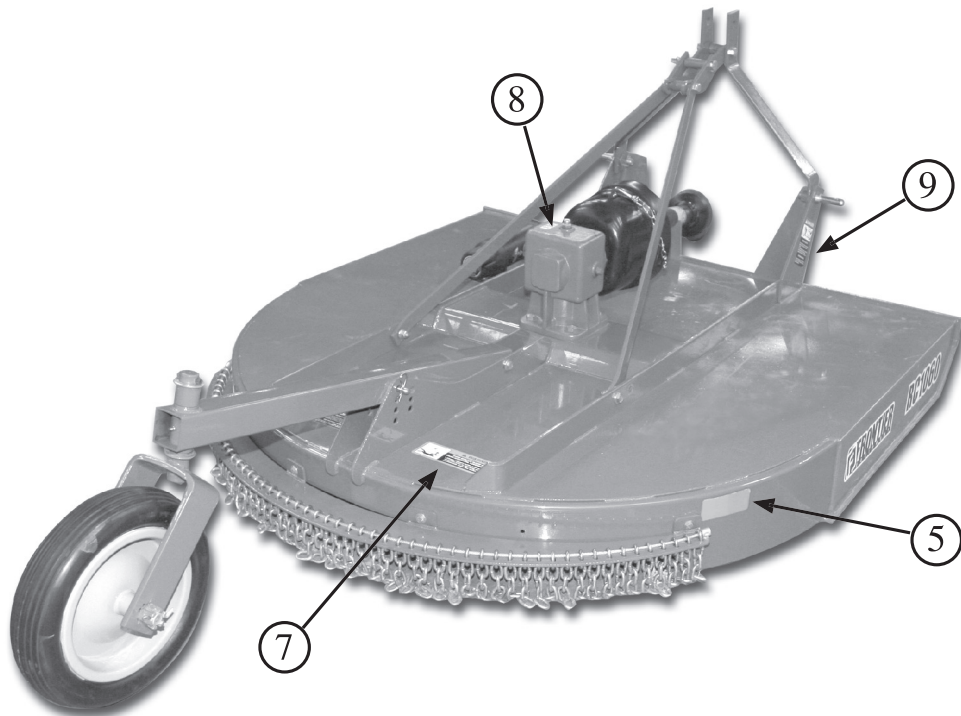

RC1060 WITH SOLID RUBBER TAILWHEEL

8 Safety and Instruction Decals

SAFETY and INSTRUCTIONAL DECALS



ATTENTION! BECOME ALERT! YOUR SAFETY IS INVOLVED!



Replace Immediately if Damaged!



③ 540 RPM
PN - ME100192



⑧ NEEDS OIL
PN - ME100197



⑨ THROWN OBJECT
PN - ME100189



⑤ RED REFLECTOR
PN - ME100195

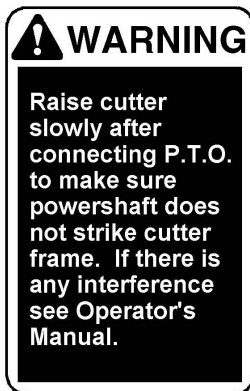

① RAISE CUTTER
PN - ME100190



④ SERIAL NUMBER



⑦ RAISE CUTTER
PN - ME100194



② ENTANGLEMENT
PN - ME100191

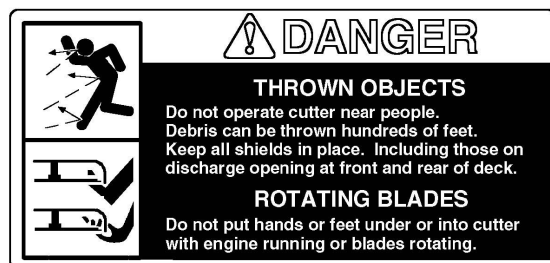

⑥ THROWN OBJECT
PN - ME100193

GENERAL DESCRIPTION

Your 10 Series Frontier Rotary Cutter has been carefully designed for cutting grass and small brush. This manual is provided to give you the necessary operation and maintenance instructions for keeping your rotary cutter in excellent operating condition. Please read this manual thoroughly. Understand the purpose of the controls and how to use them. Observe all safety precautions on the machine and as noted throughout this manual. If any assistance or additional information is needed, contact your authorized Frontier dealer. Each cutter has free-swinging blades which reduce the shock on impact when a stationary object is hit. A shear bolt through the input shaft or slip clutch equipped driveline protects the gearbox and driveline from damage.

Major components

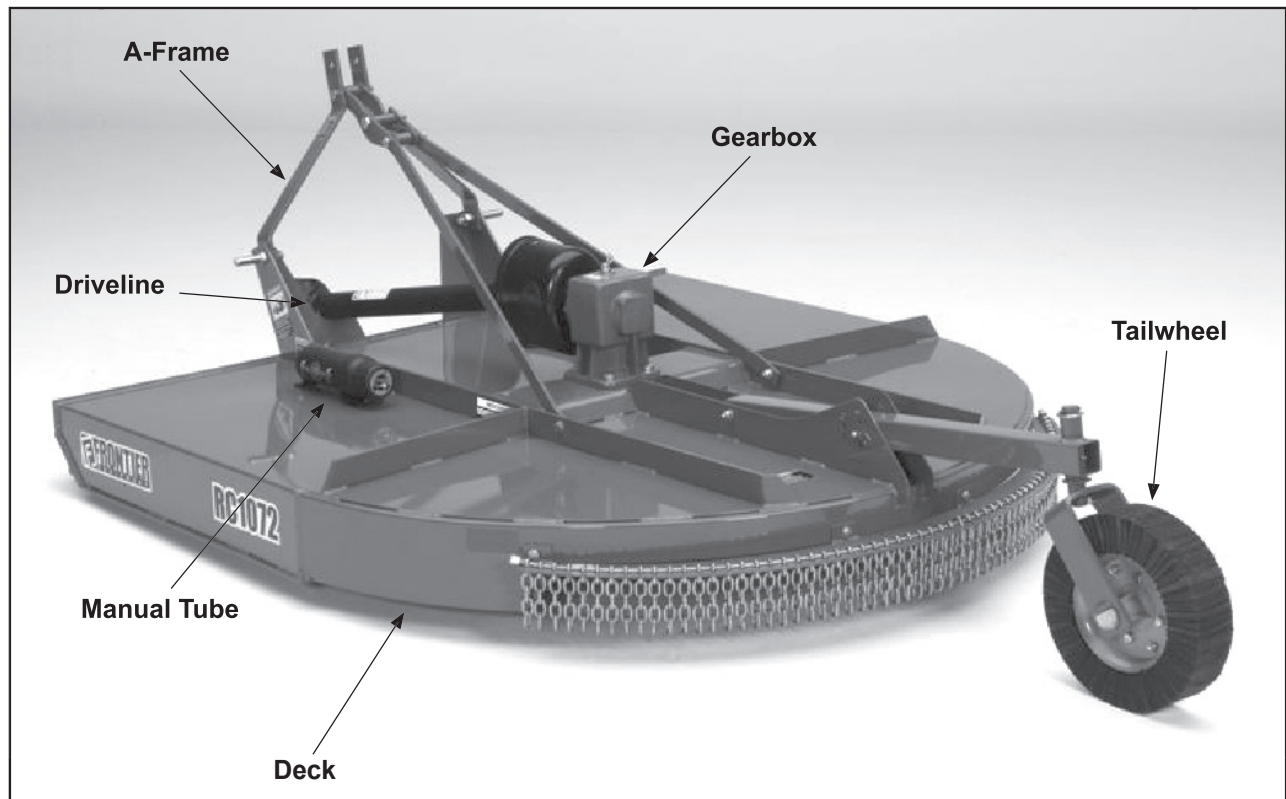

Cutter configuration: slip clutch, front and rear deflectors, iMatch hitch, and laminated tire

TECHNICAL DESCRIPTION

Model	RC1048	RC1060	RC1072
Capacity			
Cutting Width	48 inches	60 inches	72 inches
Cutting Height	1.5 to 9 inches	1.5 to 9 inches	1.5 to 9 inches
Cutting Capacity (diameter)	up to 1 inch	up to 1 inch	up to 1 inch
Cutting Chamber Depth	7.5 inches	7.5 inches	7.5 inches
Tractor Compatibility			
Tractor PTO HP Range	18 - 45	20 - 65	25 - 65
Tractor PTO	540	540	540
Hitch			
Type - Lift	iMatch or Non-iMatch	iMatch or Non-iMatch	iMatch or Non-iMatch
Category	1, adaptable to 2	1, adaptable to 2	1, adaptable to 2
Dimensions			
Overall Width, in.	51.4	63.1	75.6
Overall Length, in.	86.6	98.4	110.8
Deck Shape	Flat-open round back	Flat-open round back	Flat-open round back
Deck Type	Single	Single	Single
Approx. Weight, lb.	512	584	710
Deck Thickness, gauge	11	11	11
Skirt Thickness, gauge	11	11	11
Driveline			
Type	Shear Bolt or Slip Clutch	Shear Bolt or Slip Clutch	Shear Bolt or Slip Clutch
Gearbox			
HP Rating	45	65	65
Blades			
Thickness, inches	0.5	0.5	0.5
Width, inches	3	3	3
Type	Heat Treated Suction	Heat Treated Suction	Heat Treated Suction
Blade Tip Speed, ft./min.	13,090	12,465	14,955
Blade Holder			
Type	Round pan-type	Round pan-type	Round pan-type
Diameter, in.	24	24	36
Wheels			
Type	Solid Rubber or Laminated	Solid Rubber or Laminated	Solid Rubber or Laminated
Diameter Laminated, in.	15	15	15
Width Laminated, in.	3.75	3.75	3.75
Diameter Rubber, in.	15	15	15
Width Rubber, in.	3.75	3.75	3.75
Enclosure Options			
Front Deflector	Foot Guard/Belting or Chain	Foot Guard/Belting or Chain	Foot Guard/Belting or Chain
Rear Deflector	Belting or Chain	Belting or Chain	Belting or Chain

PREPARATION

• Selecting Tractor PTO Speed

IMPORTANT: Never operate a cutter equipped for 540 rpm PTO drive with a factor equipped to 1000 rpm PTO.

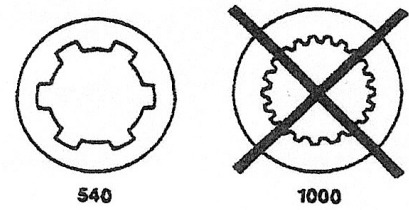

**Always run tractor at rated PTO speed.
Overspeed will cause damage to drive system.**

Refer to your tractor Operator's Manual to change PTO stub shaft, if necessary.

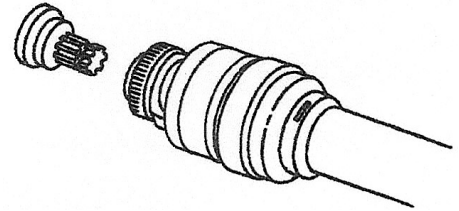

• Positioning Drawbar

IMPORTANT: To prevent damage to the driveline, remove, shorten, or place drawbar to one side. If equipped with clevis, remove it.



• Preparing the Cutter

Perform the following procedures before operating the cutter:

Gearbox

- Check oil level. (See Lubrication and Maintenance section.)
- Check hardware torque. (See Lubrication and Maintenance section.)
- Remove any material wound on gearbox shafts.
- Check oil seals for leakage.

Blades and Blade Holder

- Inspect blades for wear or damage. (See CHECKING BLADE WEAR in Service section.)
- Check blade hardware torque. (See Lubrication and Maintenance section.)
- Check blade holder hardware torque. (See Lubrication and Maintenance section.)

Hitch Pins

- Check torque on hitch pin lock nut.
- Insure all bolts on cutter are fastened securely.

Lubricating the Cutter

- Lubricate cutter and driveline. (See Lubrication and Maintenance section.)

PREPARATION

• Installing Hitch Pin Bushings for Category 1 Quick Coupler Hitch

NOTE: Install bushings on both hitch pins. Right-hand side shown. Use Frontier category 1 quick coupler bushing kit WS862500 or John Deere category 1 quick coupler bushing kit BW15056.

1. If using John Deere bushing kit BW15056, install bushing (A) over hitch pin with cross hole as shown.
2. Install bushing (B) as shown.
3. Align holes in bushings with hole in hitch pin and install roll pin (C).

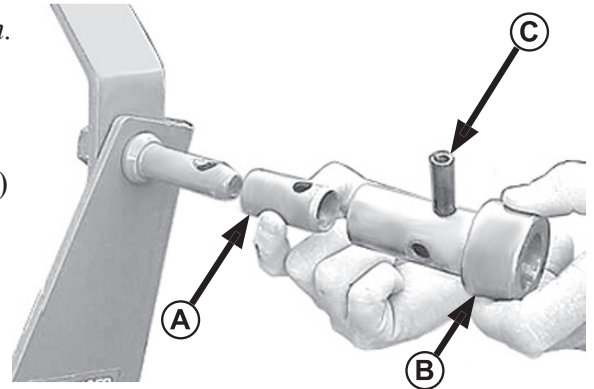

A-Bushing (not needed if using Frontier kit, WS862500)
B-Bushing
C-Roll Pin

• Using Category 2, 3-Point Hitch

Special adapter bushings are available from your John Deere dealer to accommodate tractors with category 2, 3-point hitch.

Install bushings on cutter hitch pins and tractor center link connection.

- A - Center Link Connection
- B - Hitch Pins

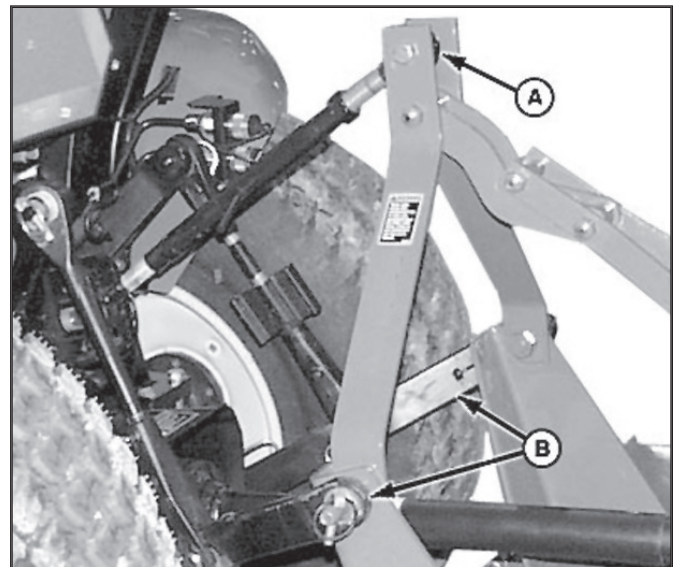

• Checking Driveline Shields

⚠ DANGER Entanglement in rotating driveline can cause serious injury or death. Disengage PTO, engage parking brake or place transmission in "PARK", shut off tractor, and remove key before working near driveline.

Check driveline shields by making sure they rotate freely.

Lubricate or repair if necessary.

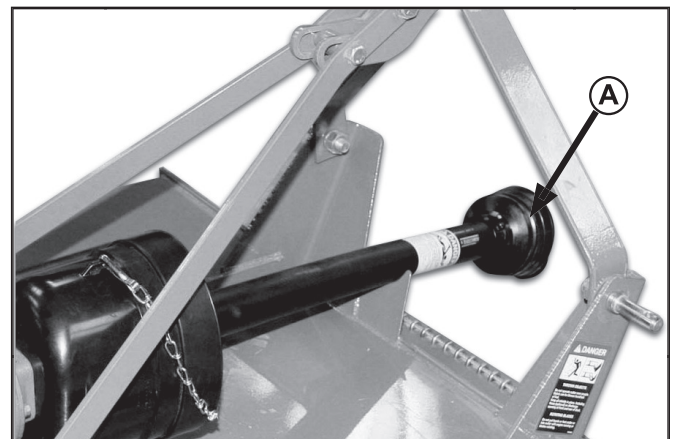

A - Driveline Shield

ATTACHING

• Attaching Cutter to Tractor with Quick Coupler Hitch

⚠ CAUTION: To avoid bodily injury or machine damage whenever an implement is attached, put transmission in PARK position and check the full range of hitch for interference, binding, or PTO separation. Do not stand between tractor and implement.

1. Slowly push hitch control lever to lower hitch until quick coupler hooks are lower than cutter hitch pins.
2. Back up tractor to cutter hitch.
3. Raise hitch high enough to engage cutter hitch pins in hooks.
4. Engage tractor parking brake and/or place transmission in "Park".
5. Shut off tractor engine and remove key.
6. See ATTACHING PTO DRIVELINE in this section.

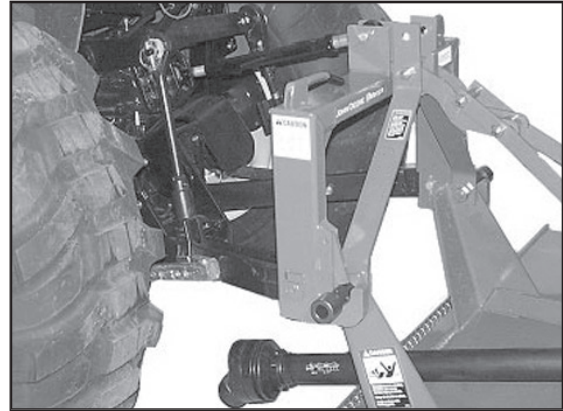

7. Start tractor engine.
8. Slowly pull hitch control lever to raise cutter. Check for interference. (See CHECKING DRIVELINE/CUTTER CLEARANCE in this section.)
9. Lower cutter to ground and adjust if necessary.

• Attaching Cutter to Tractor with Three-Point Hitch

⚠ CAUTION: To avoid bodily injury or machine damage whenever an implement is attached, put transmission in PARK position and check the full range of hitch for interference, binding, or PTO separation. Do not stand between tractor and implement.

1. Back up tractor to cutter with hitch points approximately in alignment.
2. Engage tractor parking brake and/or place transmission in "Park".
3. Shut off tractor engine and remove key.
4. Remove center link mounting hardware and hitch pin assemblies at both hitch masts.
5. Install tractor draft links on hitch pins. Secure with quick-lock pins (stored on tractor draft links.)
6. Align center link with upper hole in cutter mast straps and install center link mounting hardware.
7. Tighten all link and brace hardware on iMatch Hitch (A).
8. Non iMatch Hitch link clevis should rotate 360° freely after all hardware have been installed.

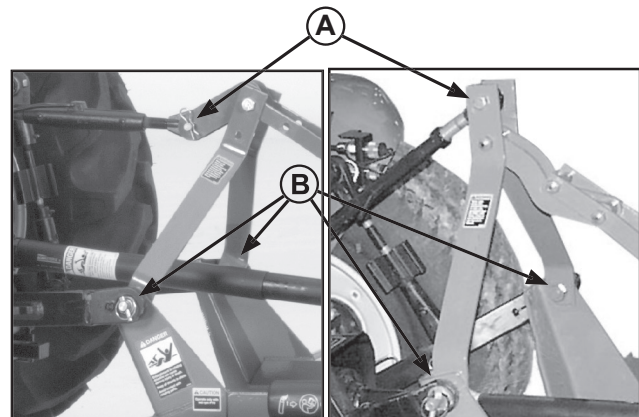

Non iMatch Hitch

iMatch Hitch

A-Tractor Center Link B-Tractor Draft Links

NOTE: Non iMatch Hitch - After installing hardware link clevis should rotate 360° freely. (if it does not rotate freely, use a shorter Cat 1 top link hitch pin)

9. See ATTACHING PTO DRIVELINE in this section.
10. Start tractor engine.
11. Slowly pull hitch control lever to raise cutter. Check for interference. (See CHECKING DRIVELINE/CUTTER CLEARANCE in this section.)
12. Lower hitch to ground and adjust center link and/or lift links if necessary. (See procedures in your tractor Operator's Manual.)

ATTACHING

• Assembling PTO Driveline Telescoping Members (If Necessary)

1. Apply multipurpose grease around outside surface of inner driveline tube (A).
2. Align driveline halves and assemble telescoping members together.
3. Apply multipurpose grease, or equivalent, to all lubrication fittings before operating. (See Lubrication and Maintenance section.)

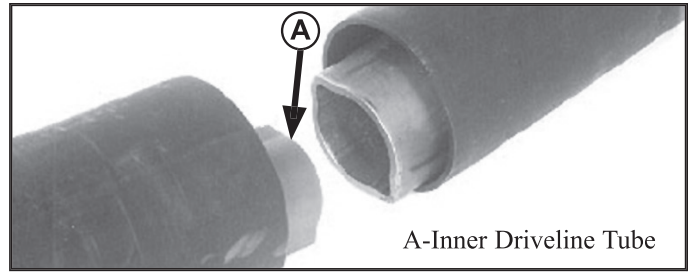

• Attaching PTO Driveline

⚠ DANGER Shut off tractor engine before attaching PTO driveline. Entanglement in rotating driveline can cause serious injury or death.

IMPORTANT: Keep driveline and powershaft splines clean of paint, dirt and chaff. Apply John Deere SD POLYUREA Grease or equivalent on tractor PTO shaft before attaching PTO driveline.

1. Shut off tractor engine.
2. Raise tractor PTO shield, if equipped.

IMPORTANT: Do not use bell on driveline to lift driveline into position. Damage to shielding can occur.

3. Support driveline, cradling it in your hand.
4. Pull collar back toward cutter. Align splines by rotating cutter driveline. Push driveline onto tractor PTO shaft until collar snaps into place.
5. Pull back on shield to make sure driveline is locked.
6. Do not pull back on collar, this will release latch.
7. Lower tractor PTO shield, if equipped.

• Checking Driveline/Cutter Clearance

IMPORTANT: Prevent driveline damage from contact with frame or machine damage from contact with tractor tires. Raise cutter slowly and check for interference. If necessary, shorten center link or lengthen lift links to provide clearance to full lift height.

1. Raise cutter slowly and check for clearance between driveline shield and cutter deck.
2. Check clearance between tractor tires and foot guards or chain deflector.

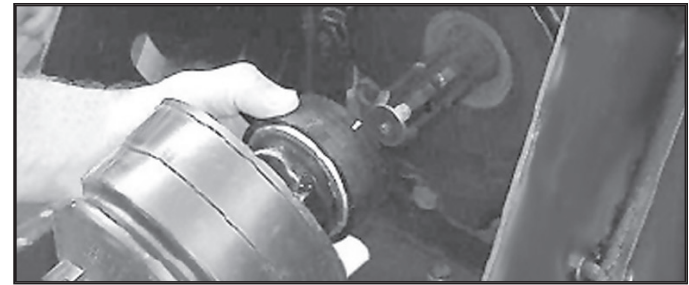

IMPORTANT: Slip clutch components must be free to rotate when necessary. After thirty days or more, linings of slip clutch may draw moisture. Linings may bond to metal parts causing slip clutch to be ineffective, resulting in machine damage.

8. Slip clutch operational check.
After the implement has been stored for thirty days or more perform the following operational check.
 - a. Loosen bolts and lock nuts progressively until tension is relieved.
 - b. To aid in determining slippage, scribe/mark a line across clutch plate and Belleville Spring.
 - c. With tractor at idle speed, engage tractor PTO drive 2 - 3 seconds. Clutch should slip without turning blades. If clutch does not slip, contact your authorized dealer.
 - d. Tighten bolts and lock nuts progressively, leaving a gap of 4mm, between clutch plate and Belleville spring.

3. Check to see if hitch height position will provide clearance desired.

NOTE:

Final adjustments should be made before operating cutter. See ADJUSTING CUTTING HEIGHT AND ANGLE in Operating the Cutter section. Center link should be installed in lowest hole at tractor end if there are multiple holes. Lift height may also be limited by installing stops on rockshaft control lever bracket.

(continued on next page)

ATTACHING

(continued from previous page)

4. Shorten center link or lengthen lift links to provide clearance. (See your tractor Operator's Manual.)

IMPORTANT: PTO driveline may be too long for some tractor models, causing tractor transaxle damage. Hold driveline sections parallel to each other and check for a minimum of 6 inches overlap.

5. Raise and lower cutter slowly to check for binding or interference. Check cutter-to-tractor driveline telescoping length to ensure it does not bottom out. Modify driveline if necessary. (See MODIFYING PTO DRIVELINE in Assembly section.)

DETACHING

• Detaching Cutter from Tractor

⚠ CAUTION: To prevent personal injury caused by unexpected movement:

- a. Park machine on a level surface.
 - b. Engage tractor parking brake and/or place transmission in "Park".
 - c. Disengage PTO.
 - d. Shut off tractor engine and remove key.
1. Park cutter on a level surface, or block tail-wheel so machine cannot roll after detaching from the tractor.
 2. Slowly push hitch control lever to lower cutter close to the ground.
 3. Engage tractor parking brake and/or place transmission in "Park".

⚠ DANGER Shut off tractor engine before detaching PTO driveline. Entanglement in rotating driveline can cause serious injury or death.

4. Shut off tractor engine and remove key.
5. Raise tractor PTO shield, if equipped.

IMPORTANT: Do not use plastic shield on driveline to hold driveline in position. Damage to shielding can occur.

6. Pull collar back toward cutter and slide drive line off tractor shaft.

7. Support and collapse driveline completely and lower onto PTO holder.
8. Lower tractor PTO shield, if equipped.

(continued on next page)



DETACHING

• Tractor with Quick Coupler Hitch

1. Raise both latch control levers on quick coupler (A).
2. Start tractor engine.
3. Lower cutter to the ground. Continue lowering quick coupler until hooks clear cutter hitch pins.
4. Carefully drive tractor away.

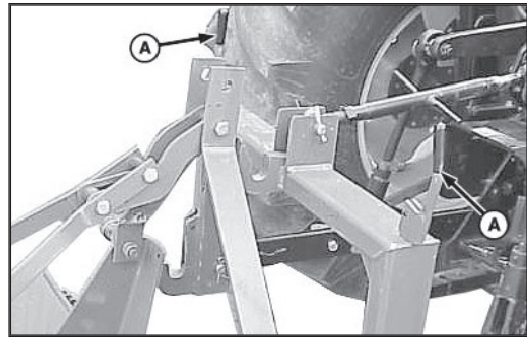

• Tractor with Three-Point Hitch

1. Remove quick-lock pins from hitch pins and install in storage position on tractor draft links.
2. Remove and lower tractor draft links from hitch pins.
3. Disconnect center link from mast straps. Position tractor center link in transport location. Reinstall center link pin/hardware.
4. Carefully drive tractor away.

IMPORTANT: After thirty days or more, linings of slip clutch may draw moisture. Linings may bond to metal parts causing slip clutch to be ineffective. Loosen all lock nuts on slip clutch. This will relieve spring load on the discs reducing this problem during storage. Preparing cutter for operation, refer to Assembling Slip Clutch in Service section, page 22.

OPERATION

General Safety

Only qualified people should operate this machine. Wear close fitting clothing and safety equipment appropriate to the job. It is recommended that tractor be equipped with Rollover Protective Systems (ROPS) and a seat belt be used. Before beginning operation, clear work area of objects that may be picked up and thrown. Check for ditches, stumps, holes or other obstacles that could upset tractor or damage rotary cutter. Always turn off tractor engine, set parking brake, and allow rotary cutter blades to come to a complete stop before dismounting tractor.

• Preparing Cutter for Operation

⚠ DANGER To help prevent severe injury or death to you or someone else:

- a. Do not engage tractor PTO when cutter is in fully raised position (transport position).
- b. Keep all persons away from machine when raising and lowering cutter.

IMPORTANT: To avoid damaging the machine from impact on ground when lowering, adjust rate at which hitch will lower.

1. Adjust tractor rockshaft rate-of-drop. Allow at least two seconds for machine to lower from full lift height to the ground. (See your tractor Operator's Manual.)
2. If equipped, disengage tractor hitch/rockshaft control lever from transport lock position and lower cutter to the ground. (See your tractor Operator's Manual.)
3. Adjust tractor lift links to level machine side-to-side. (See your tractor Operator's Manual.)
4. Adjust cutting height and angle. (See Adjusting Cutting Height and Angle in this section.)

OPERATION

• Adjusting Cutting Height and Angle

⚠ DANGER Help prevent bodily injury or death caused by entanglement in rotating driveline or blades. Entanglement in rotating driveline or being struck by blades can cause serious injury or death. Before making any adjustments:



- Lower machine until rear wheel just touches or is slightly above ground.
- Engage tractor parking brake and/or place transmission in “PARK”.
- Disengage PTO.
- Shut off tractor engine and remove key.
- Wait until all moving parts have stopped.
- Disconnect PTO driveline from tractor.

- Loosen bolt and lock nut (B), remove bolt, washers and lock nut (A), raise tailwheel to highest position and install bolt, washer and lock nut (A).
- Using rockshaft control lever, position front of cutter at desired cutting height at location.
- Adjust depth stop. (See your tractor Operator’s Manual.)
- Adjust center link so rear of cutter is approximately 2 inches (51 mm) higher than front.

NOTE:

The rotary cutter should be operated at the highest position which will give optimal cutting results. This will help prevent the blades from striking the ground, reducing blade wear and undue strain on the cutter. For best results under heavier cutting conditions, always tilt the rotary cutter approximately 2 inches

(51mm) lower in the front. This tilt decreases horsepower requirements and increases potential ground speed. When fine shredding is desired, adjust rotary cutter deck level or slightly lower in the rear. This will keep the foliage under rotary cutter until thoroughly shredded. More power is required for shredding.

- Lower tailwheel to support rear of the cutter.
- Install bolt, washers and lock nut (A) into one of seven holes (C) that aligns with hole in wheel support.
- Reinstall bolt, washers and lock nut. Tighten lock nut. (A)

NOTE:

The tailwheel supports the rear of the machine and the draft links support the front to allow the cutter to follow the ground contour.

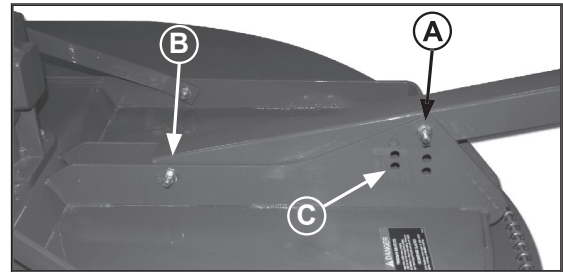

A-B Lock Nut, Washers, Bolt C- Adjustment hole

Each rotary cutter can be adjusted to several cutting heights from 1.5 inches to 9 inches of cutting height by moving the rockshaft control lever in conjunction with moving the tailwheel adjustment bolt among the height adjustment holes (see photo above)

IMPORTANT: Loosening the center link may allow the driveline to contact the cutter frame or tractor tires to contact the foot guards or chain shield. Raise the cutter slowly and check for interference. Lengthen tractor lift links to provide clearance to full height.

NOTE: Lift height may also be limited by installing stops on rockshaft control lever bracket.

- Lengthen tractor lift links, if necessary, to provide clearance.
- For cutter equipped with iMatch Hitch, adjust tractor center link until bushing is centered in slot.

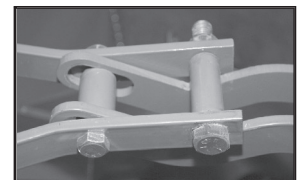

OPERATION

• Follow Safe Operating Procedures

1. Perform BEFORE EACH USE maintenance in the Lubrication and Maintenance section.
2. Start tractor per tractor operator's manual.
3. Raise/lower 3-point hitch to place cutter in working position.
4. Look to be sure no one is near cutter.
5. With tractor at idle speed, slowly engage PTO drive.

⚠ DANGER STAY CLEAR OF ROTATING DRIVELINE. DO NOT OPERATE WITHOUT DRIVELINE SHIELDS IN PLACE AND IN GOOD CONDITION. FAILURE TO HEED THESE WARNINGS MAY RESULT IN PERSONAL INJURY OR DEATH.

6. Set tractor throttle for appropriate PTO speed (540RPM).

⚠ DANGER ROTATING CUTTER BLADES. STAND CLEAR UNTIL ALL MOTION HAS STOPPED. TO AVOID AN ACCIDENTAL FALL FROM TRACTOR AND POSSIBLE INJURY BY MOWER, IT IS RECOMMENDED THAT TRACTOR BE EQUIPPED WITH ROLLOVER PROTECTIVE SYSTEM (ROPS) AND A SEAT BELT BE USED BY THE OPERATOR FOR ALL MOWING OPERATIONS.

7. Place tractor in gear and proceed forward.

Note:

Tractor forward speed should be controlled by gear selection, not engine speed. For maximum cutting efficiency, forward speed should allow cutter to maintain a constant, maximum blade speed. If cutter stalls or tractor engine bogs, disengage PTO. Before re-engaging PTO, position cutter in a cut area and reduce tractor throttle to idle. If rotary cutter continuously stalls, select lower gear and/or increase cutting height.

• Keep Riders Off Machine

⚠ DANGER Keep riders off. Riders are subject to injury or death such as being struck by foreign objects and being thrown off the machine. Riders may also fall off and be run over by machine. Riders also obstruct the operator's view resulting in the machine being operated in an unsafe manner.

• Follow Safety Operating Procedures

⚠ DANGER To help prevent severe injury or death to you or someone else:

Never operate cutter when other people are in the vicinity. Debris can be thrown hundreds of feet. Keep all deflectors in place. Including those on discharge opening at front and rear of deck. Before starting machine, lower to the ground. Engage tractor PTO and gradually increase the speed.

Operate tractor at rated PTO speed. If engine speed is too slow or too fast, machine may not perform properly.

Where conditions make it necessary to slow ground speed, shift to a lower gear rather than reducing engine speed. The engine will maintain rated speed and keep cutter running at optimum cutting speed.

Operate machine from tractor seat only.

Never adjust machine while in motion.

Slow down when turning or traveling over rough ground.

Avoid holes when operating on hillsides. Tractor roll-over could result.

Shut off tractor engine and engage tractor parking brake and/or place transmission in "Park" when leaving tractor. Remove key when leaving tractor unattended.

Components behind shields may rotate several minutes after power is shut off. Look and listen for evidence of rotation before removing shielding.

LUBRICATION and MAINTENANCE

• Lubricating and Maintaining Machine Safely



DANGER Help prevent bodily injury or death caused by entanglement in rotating driveline or blades. Entanglement in rotating driveline or being struck by blades can cause serious injury or death.

Components will be hot after operation.
Let all components cool before servicing.

Replace all shields after lubricating or servicing.

• Maintenance Check List

Perform scheduled maintenance as outlined below. Lower machine to ground, turn off tractor and set parking brake before doing maintenance inspections or work. All bolts should be torqued as recommended in the Torque Specifications unless otherwise indicated.

• Maintenance Before Each Use



CAUTION: Do not clean, lubricate, or adjust machine while it is in motion.

1. Check tractor tire air pressure. Refer to tractor operator's manual.
2. Check blades and spindles to be sure that no foreign objects such as wire or steel strapping bands are wrapped around them.
3. Check blade bolts for tightness. (Tighten to 425 ft. /lbs.)

IMPORTANT: Operating with loose blade hardware will damage the blade holder and blades.

- a. RC1048: Remove tailwheel tube assembly support. (See REMOVING AND INSTALLING TAILWHEEL SUPPORT in Service section.)
- b. Locate blade hardware under hole.

Note: Blade bolt tightening requires a 1 1/2" socket with extension, a torque multiplier, and a torque wrench to torque nut to 425 ft./lbs.

- c. RC1048: Reinstall tailwheel tube assembly support in original position.
4. Inspect blades for wear. (See SERVICE SECTION Checking Blade Wear). Always replace both blades on blade holder with genuine Frontier parts.
 5. Make certain driveline shields are in place and in good repair.
 6. Inspect tailwheel for wear, damage, or foreign objects. (Repair or replace if necessary.)
 7. Before each use refer to LUBRICATION LOCATIONS AND INTERVALS in this section.
 8. During operation, listen for abnormal sounds which might indicate loose part, damaged bearings, or other damage.

• Maintenance After Each Use

1. Clean all debris from rotary cutter especially under side of deck. When cleaning underside of deck, securely block machine into position.

IMPORTANT: To help prevent structural damage caused by loose hardware, check all hardware after first eight (8) hrs of use and tighten all hardware to specifications.

• Observe Lubrication Symbols

Lubricate with John Deere SD POLYUREA GREASE or equivalent SAE multipurpose-type grease (unless otherwise specified) at hourly intervals indicated on the symbols.

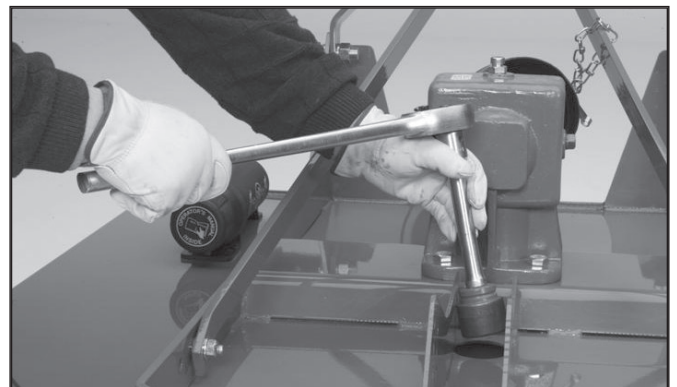

LUBRICATION and MAINTENANCE

• Lubrication Before Each Use

1. Driveline Universal Joints

a. Apply multi-purpose grease with a grease gun.

2. Driveline Guard

b. Apply 2-3 shots of multipurpose grease with grease gun to plastic fitting.

3. Driveline Profile

c. Disconnect PTO Driveline.

d. Pull two sections apart.

e. Apply thin coat of multi-purpose grease to inside of female section.

f. Re-assemble sections.

Note: Pull each section to be sure driveline and shields are securely connected. Make certain PTO shielding is in good condition. Do not grease outer or inner plastic shields.

4. Tailwheel Pivot Tube

g. Apply multi-purpose grease with grease gun.

5. Tailwheel

h. Apply multi-purpose grease with grease gun.

6. Gearbox

i. Check oil level by removing oil level check plug on side of gearbox.

j. Add EP80-90W gear oil if necessary to bring oil level to check plug hole.

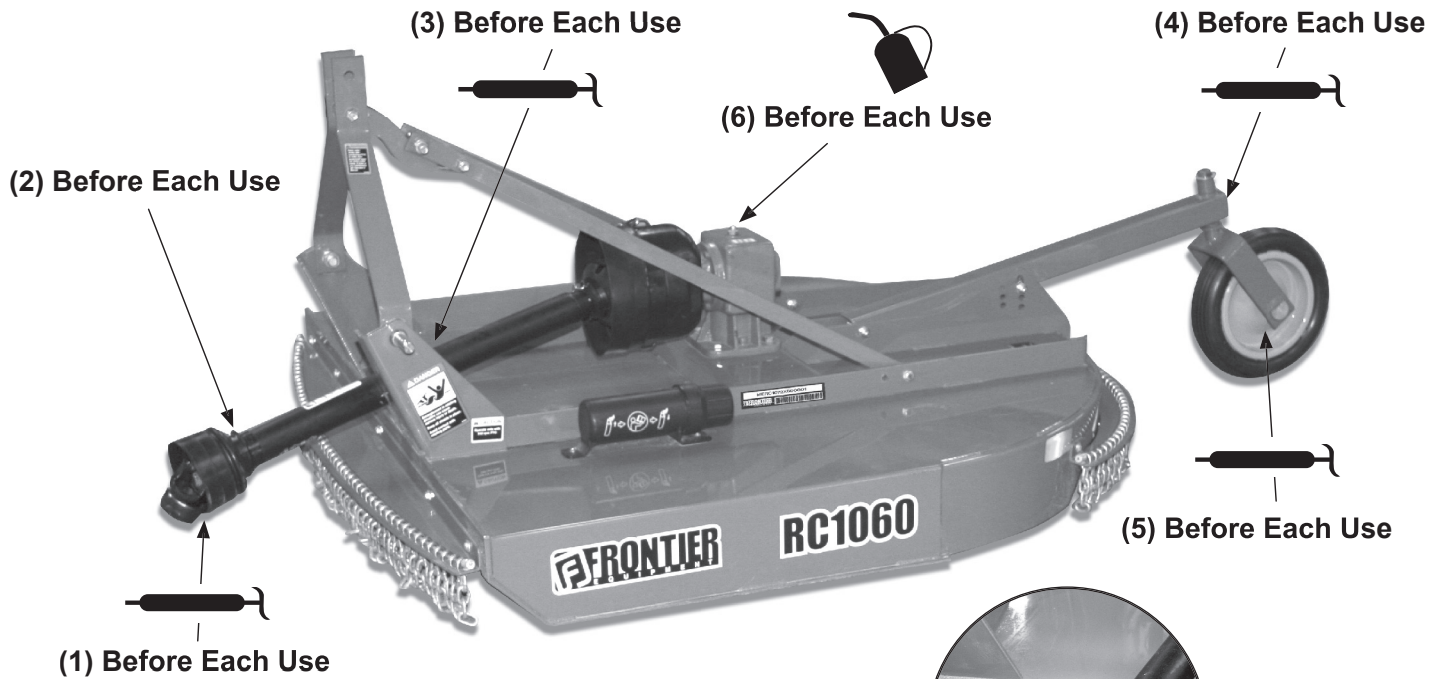

d. Pull two sections apart.

SERVICE

• Practice Safe Service Procedures

⚠ CAUTION: To help prevent personal injury caused by unexpected movement, be sure to service machine on a level surface.

Before servicing or adjusting machine connected to a tractor:

1. Lower machine to the ground.
2. Engage tractor parking brake and/or place transmission in “Park”.
3. Disengage PTO.
4. Shut off tractor engine and remove key.
5. Wait until all moving parts have stopped.
6. Disconnect PTO driveline from tractor.

The blades and blade pan may rotate for several minutes after PTO is shut off. Look and listen for rotating driveline to stop before working on the cutter.

When servicing blades or blade pan, it will be necessary to work underneath cutter. Be sure to support cutter frame at all four corner locations with safety shop stands to prevent accidental lowering. Do not position safety stands under wheel support because these components can rotate.

• Disassembling and Assembling Driveline Shields

1. Separate telescoping parts.
2. Remove driveline shield screw (B).
3. Rotate cone to align tab (C) with hole (A) and slide shield rearward off of driveline.
4. Assemble in reverse order.

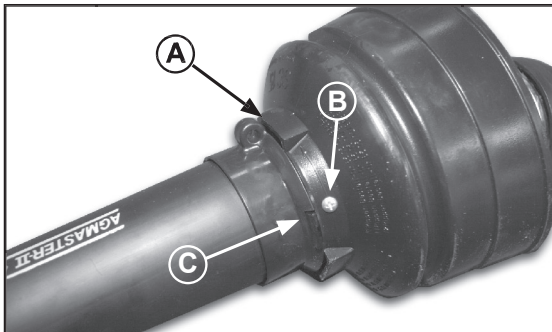

• Disassembling and Inspecting Slip Clutch

1. Remove slip clutch driveline.
(See procedure in this section.)

NOTE:

Belleville springs, which are part of the clutch, keep tension on all components. When disassembling, release tension by loosening hardware progressively.

2. Loosen bolts and lock nuts progressively until tension is relieved.
3. Friction disks may appear to be part of the hub or yoke, tap lightly on edge to separate.
4. Inspect clutch components for wear or damage. Repair or replace parts as necessary.

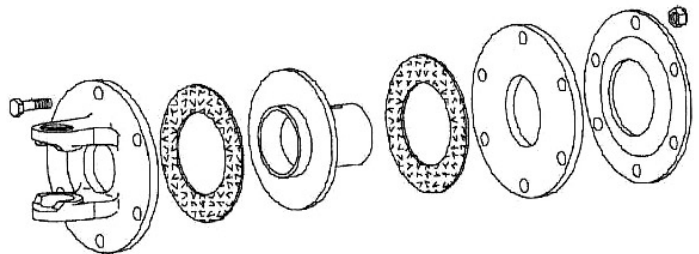

• Assembling Slip Clutch

Assemble slip clutch in reverse order of disassembly using the following instructions:

1. Install belleville spring with concave side facing away from yoke end.

IMPORTANT: To avoid driveline damage, **DO NOT** overtighten bolts and lock nuts. A gap must be left between clutch plate (B) and belleville spring (C).

2. Tighten bolts and lock nuts progressively, leaving a gap (A) 4mm, between clutch plate (B) and Belleville spring (C).

(Service continued on next page)

SERVICE

(Service continued from previous page)

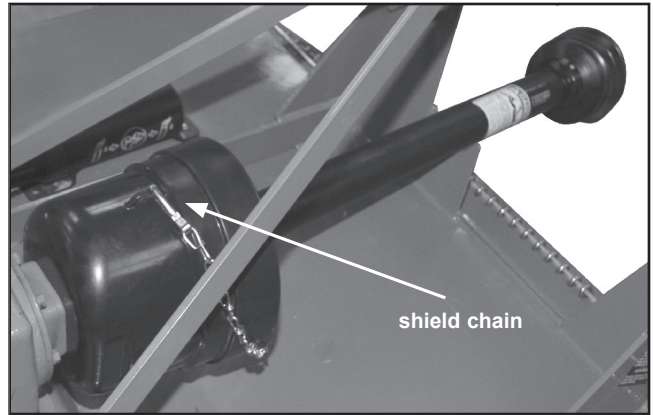
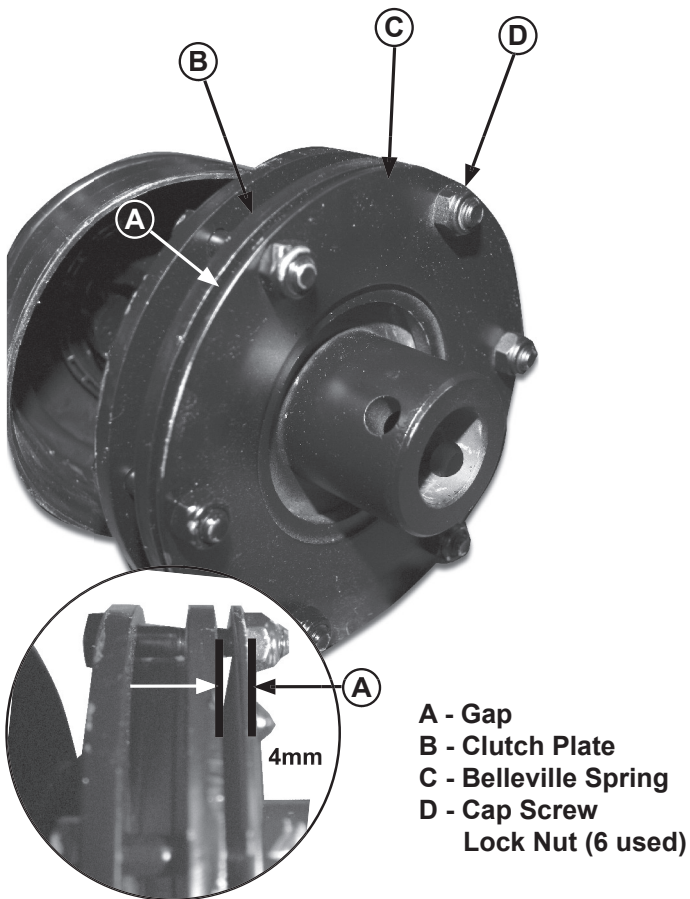

(Disconnect driveline shield chain)

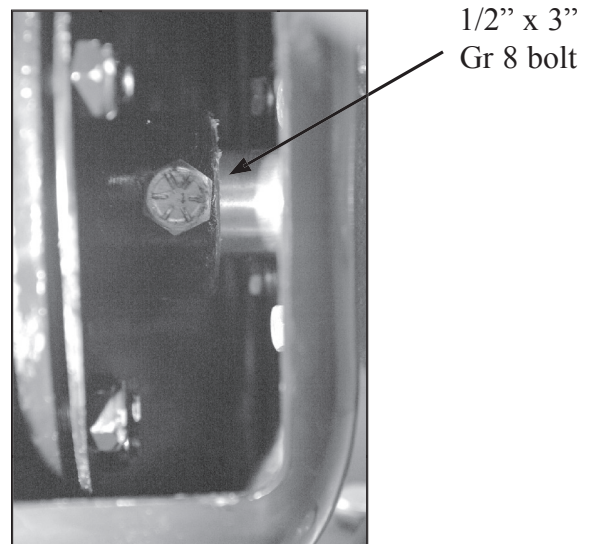

• Removing and Installing Driveline-Slip Clutch

1. Disconnect driveline shield chain.
2. Open access panel on shield.
3. Remove driveline assembly from gearbox output shaft by removing 1/2" x 3" Gr 8 bolt and lock nut.
4. Make repairs as necessary:
 - a. Slip clutch service - See DISASSEMBLING AND INSPECTING SLIP CLUTCH in this section.
 - b. Driveline repair - See your John Deere dealer.

IMPORTANT: Apply multipurpose grease on gearbox input shaft. 1/2" x 3" Gr 8 bolt and lock nut required to attach driveline to gearbox input shaft.

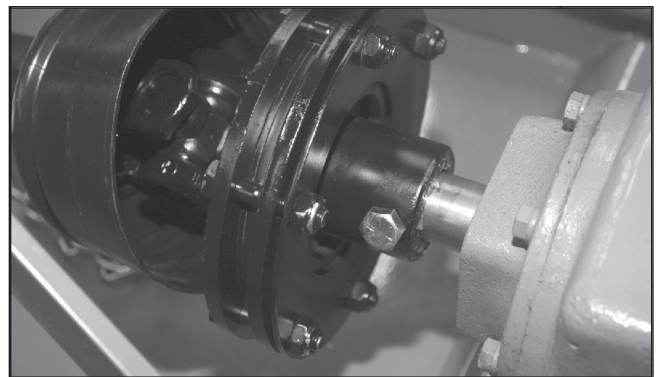

NOTE: Slip clutch shield removed for illustration purposes.

5. Install driveline in reverse order of removal.

SERVICE

• Removing and Installing Driveline-Shear Bolt

1. Disconnect driveline shield chain.
2. Bend back driveline shield cone.
3. Remove shear bolt and lock nut.
4. Push driveline onto input shaft toward gearbox and remove snap ring.
5. Pull driveline from gearbox shaft.
6. Replace or repair as necessary.
7. Install in reverse order of removal.

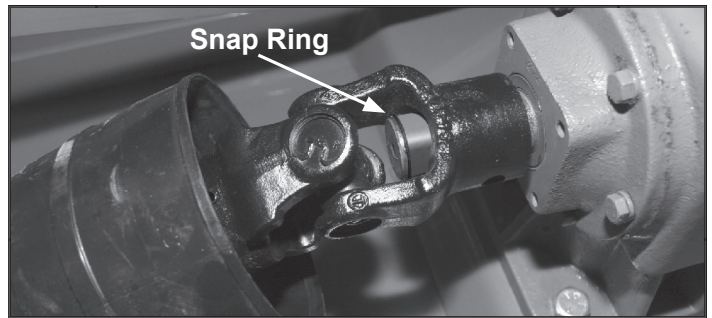

• Replacing Driveline Shear Bolt

IMPORTANT: Avoid shear bolt failure at start up by engaging the PTO slowly at low engine rpm.

If shear bolt fails:

1. Bend back driveline shield cone.
2. If necessary remove sheared bolt with hammer and punch and realign holes in yoke and shaft.
3. Replace with 1/2" x 3" Gr 2 bolt and lock nut.

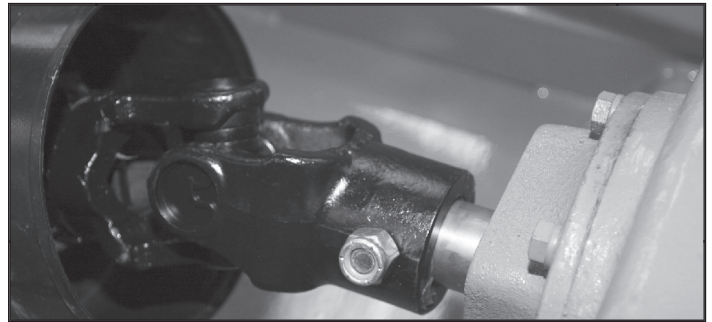

NOTE: Driveline shield pulled back for illustration purposes. Cutter drive components are protected from shock loads by a shear bolt.

• Removing and Installing Tailwheel Support

⚠ CAUTION: When removing and installing tailwheel support, it will be necessary to support the cutter. Before servicing cutter, refer to **PRACTICE SAFE SERVICE PROCEDURES** at the beginning of this section.

1. Remove 1/2" lock nut, washers and 1/2" x 4" bolt (A).
2. Remove tailwheel support.
3. Install tailwheel support in reverse order.

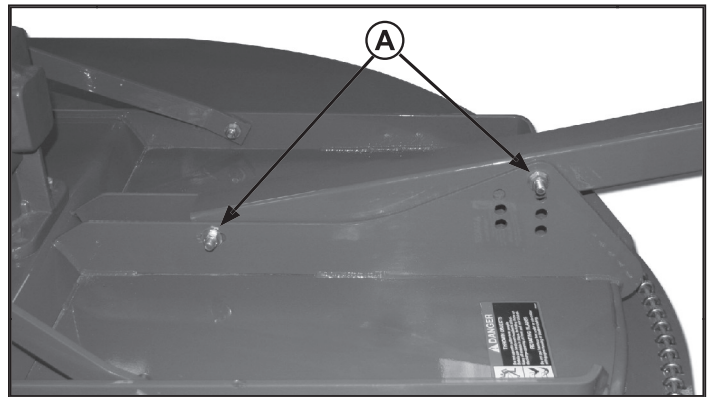

• Checking Blade Wear

IMPORTANT: Operating with blades that are not alike will cause vibration. Always replace worn or broken blades in pairs. Never replace a single blade. Check blades regularly for wear or breakage.

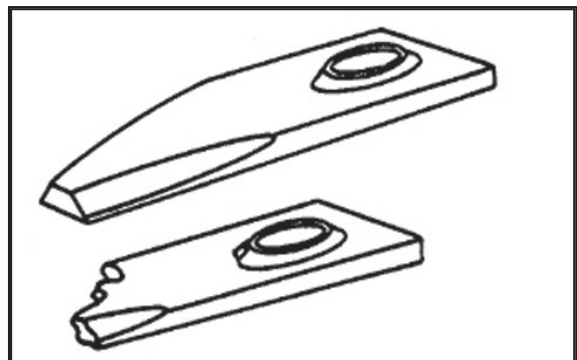

SERVICE

• Replacing Blades

IMPORTANT: Operating with loose blade hardware will damage the blade pan and blades. Whenever the blades have been removed or replaced, blade hardware **MUST** also be replaced. Always use genuine Frontier parts. Check blade hardware torque after one hour of operation and every eight (8) hours thereafter.

NOTE: Suction blades have cutting edge on one side only. Note blade rotation when installing blades. (See DIRECTION OF BLADE ROTATION in this section.)

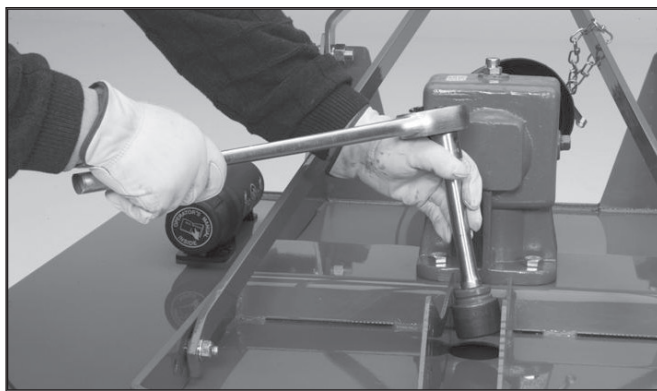

RC1048: Tailwheel support must be removed to locate blade access hole.

1. RC1048: Remove tailwheel support. (See REMOVING AND INSTALLING TAILWHEEL SUPPORT in this section.)
2. Manually rotate driveline to align lock nut with access hole in top of deck. Discard mounting hardware.
3. Install new hardware and tighten lock nut to 425 ft-lbs.
4. RC1048: Install tailwheel support.

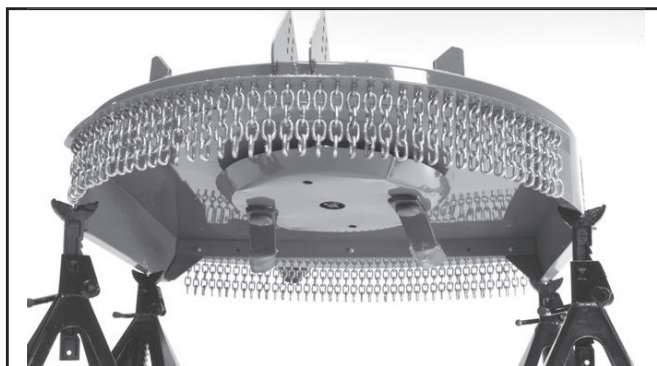

• Direction of Blade Rotation

IMPORTANT: Cutter shown is viewed from the top. Take special note of blade rotation shown by the arrow.

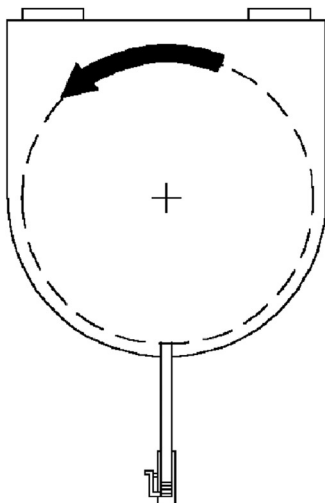

CAUTION: When replacing blades, blade hardware and blade pan it will be necessary to work underneath cutter. Be sure to support cutter frame at all four corner locations with safety shop stands to prevent accidental lowering. Do not position safety stands under wheel support because these components can rotate.

SERVICE

• Replacing Blade Pan

1. Remove the blades. (See Replacing Blade in this section.)
2. Remove cotter pin from output shaft of the gearbox.
3. Loosen castle nut to the bottom of the output shaft (A). Do not remove castle nut as it must hold the blade pan when it becomes loose.
4. Tap with a hammer around the hub using a block of wood as shown in photo.

Note: The output shaft of the gearbox is tapered. A few taps around the hub will loosen the blade pan.

5. Remove castle nut slowly and allow the blade pan to be removed.
6. Remove blade pan.

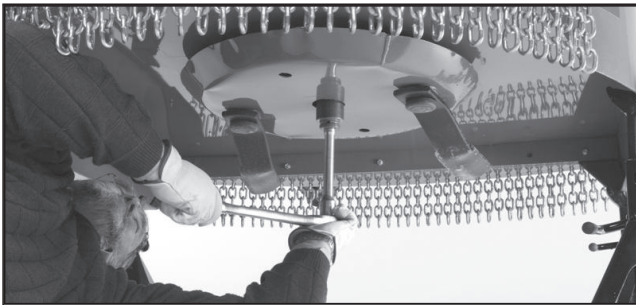
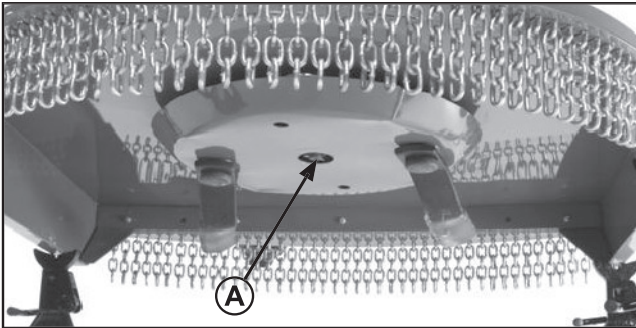

7. To reinstall blade pan, reverse the above steps. Be sure to tighten the castle nut and replace the cotter pin.
8. Replace blades. (See Replacing Blade in this section.)

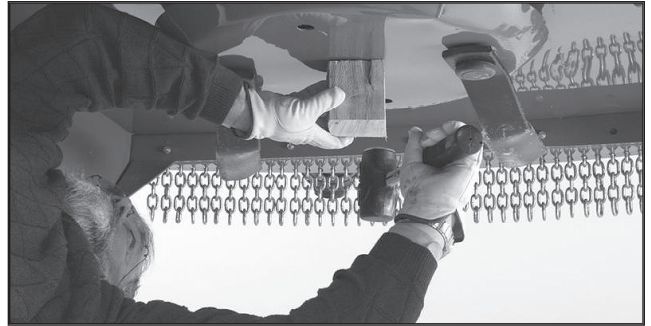

• Replacing Tailwheel Pivot/Spindle

1. Remove 1/2" lock nut, washer and 1/2" x 4" bolt.
2. Raise tailwheel to highest position and replace hardware.
3. Remove roll pin and washer (A).
4. Slide tailwheel assembly out of tailwheel support tube.
5. Replacing tailwheel, reverse the above steps.

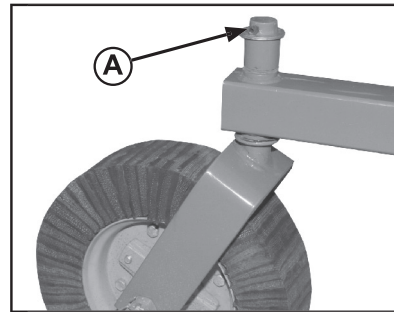

STORAGE

• At The End Of Your Cutting Season

1. Drain and change the oil in the gearbox.
2. Check (and replace where necessary) blades, bolts, and nuts on the cutter.
3. Clean cutter and touch up any rust spots that may have appeared.
4. Replace any safety decals if damaged.
5. Store rotary cutter in a clean dry location.

ASSEMBLY

• Perform Predelivery Service Safely

⚠ CAUTION: Understand the predelivery procedure before doing the work.

During the assembly, test, and adjustment procedures, it may be necessary to operate drives and hydraulic systems. Stay clear of machine elements when raising or lowering machine and during operation of drivelines.

Practice good communication with other service technicians. Be aware of their actions and alert them to potential hazards.

Never lubricate, service, or adjust machine while it is running. Keep hands, feet, and clothing away from power-driven or hydraulically operated parts. If it is necessary to inspect the machine while it is in operation, be alert to moving parts in the immediate area.

• Remove Shipping Dunnage and Parts

⚠ DANGER To help prevent bodily injury from accidental lowering of the cutter, attach a lifting strap or chains to cutter rear support frame and a hoist.

1. Remove loose parts attached to the cutter on the underside of the deck and remove additional hardware from inside of the OM tube.
2. Wrap lifting strap or chains around cutter rear support frame and attach to a hoist.
3. Lower machine onto 4 inch wood blocks.
4. Remove all shipping bands, wires and loose parts from around the cutter.
5. Remove shipping stands from cutter by removing hitch pins (A) and 1/2" bolts (B). Discard shipping stands, flat washers and bolts.
6. Install hitch pins and tighten to specified torque.

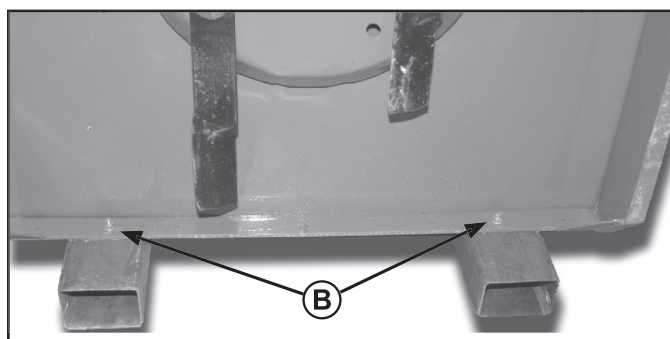

ASSEMBLY

• Assemble Hitch

1. Rotate hitch up.
2. Install hitch pivot bushing, bolt, lock nut and tighten.

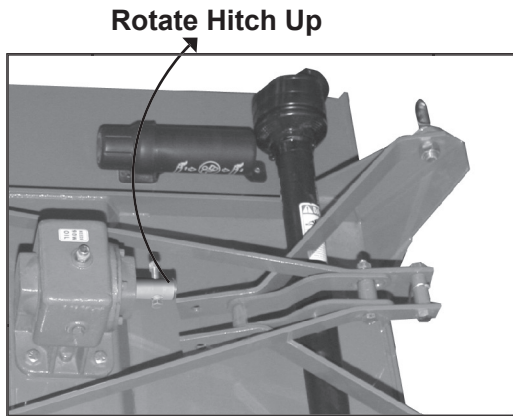

IMPORTANT: Please do not over tighten hardware.

3. Attach lift arm brace to frame using 1/2" x 13/4" bolt, bushing, washers and lock nut.

a. iMatch Hitch

Install bolt, bushing, and lock nut into hole and tighten to specifications. (A) see photo below

b. Non-iMatch Hitch

Install bolt, bushing, and lock nut into hole and tighten to specifications. (B) see photo below

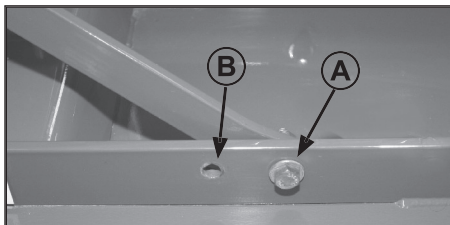

3. Repeat on opposite brace.
4. Tighten all link and brace hardware (A).
5. Attach lift arm brace (A) to frame using 1/2" x 13/4" inch bolt (C), bushing (B), flat washer (E), and lock nut (D). Tighten bolt to specifications.

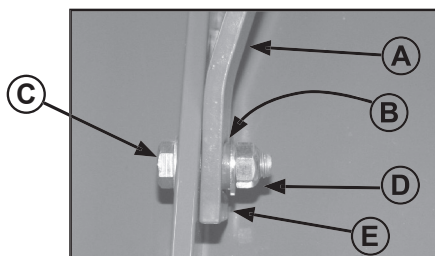

- A - Brace
- B - Bushing
- C - 1/2" x 13/4" bolt Gr5
- D - Lock Nut
- E - Washer

6. Repeat on opposite brace.
7. Tighten all link and brace hardware (A).

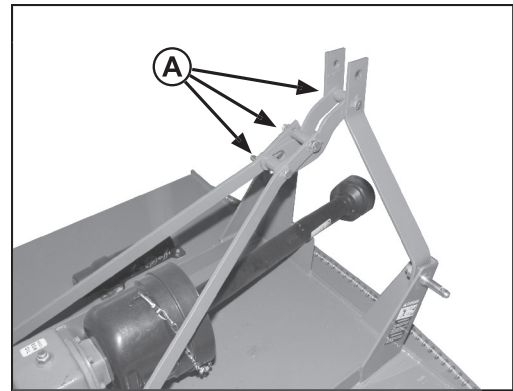

IMPORTANT: Please do not over tighten hardware.



iMatch Hitch

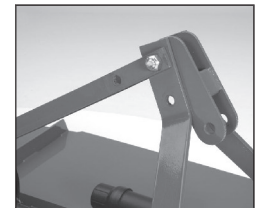

Non-iMatch Hitch

• Install Tailwheel Support

1. If necessary remove tailwheel support from shipping position.
2. Place tailwheel support between brackets on deck.
3. Install 1/2" x 4" bolt, washers and lock nut. (A)
4. Install 1/2" x 4" bolt, and lock nut (C) into one of seven holes (B) that aligns with hole in wheel support. (See Adjusting Cutting Height and Angle in Operation the Cutter section.)
5. Tighten hardware.

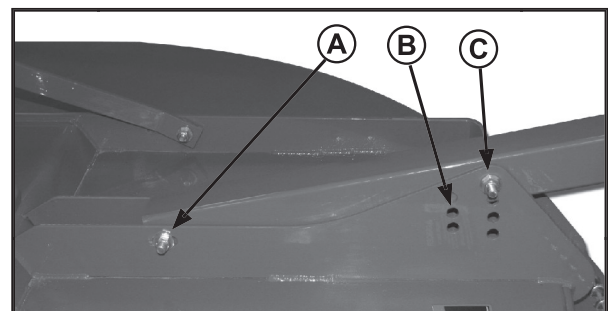

ASSEMBLY

• Install Tailwheel

1. If necessary, attach using axle bolt, castle nut, and cotter pin.
2. Tighten hardware.

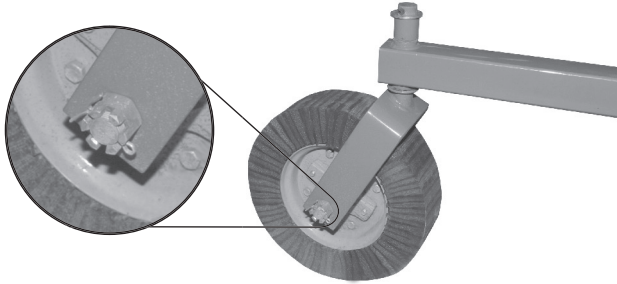

• Install Driveline

1. Remove snap ring and shear/retaining bolt from gearbox input shaft or PTO shaft.
2. Remove paint from gearbox input shaft.
3. Install slip clutch shield (if equipped).
 - a. Open access panel on shield.
 - b. Attach shield to gearbox using four 5/16" x 3/4" bolt Gr2 and flat washers. Tighten to specifications.
4. Install driveline. (See REMOVING AND INSTALLING DRIVELINE in Service section.)

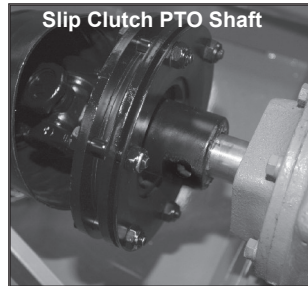
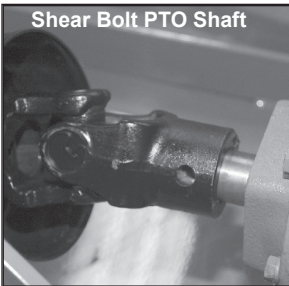
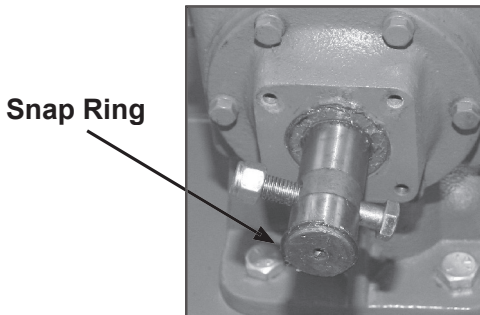

Note: Driveline shield pulled back for illustration purposes.

• Fill Gearbox

IMPORTANT: Cutter is shipped without gearbox lubricant. DO NOT operate the cutter without filling gearbox with specified amount of lubricant listed below, or gearbox will be damaged. (See Lubrication and Maintenance section).

1. Remove breather plug (A) from filler hole.
2. Fill gearbox according to initial fill with 32 ounces of EP80W-90 gear oil.

IMPORTANT: Oil will move into lower cavity of gearbox during initial operation. Check oil level after 30 minute break-in period and before every use.

3. After approximately 30 minutes of initial operation, remove check plug (B) and check oil level. Oil should just seep from check plug hole.
4. Add oil if necessary and replace plug (A).

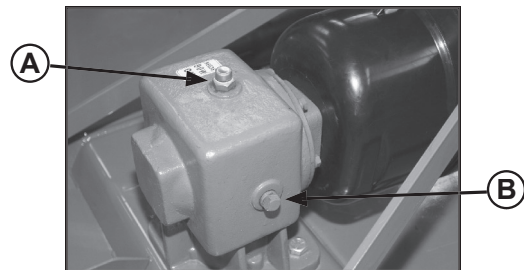

**A - Breather Plug
B - Check Plug**

• Install Front Deflector-Chains (If Equipped)

IMPORTANT: Install hardware with lock nuts and flat washers on the outside of cutter.

1. Install deflector using provided bolts, flat washers, and lock nuts. Insert bolts from inside out of rotary cutter. Tighten hardware to specifications in torque chart.

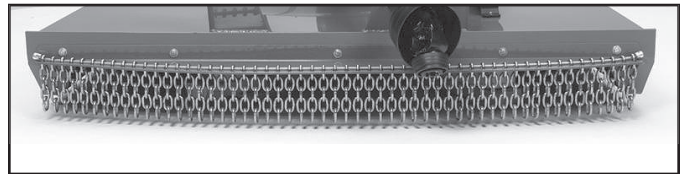

ASSEMBLY

• Install Front Deflector-Rubber (If Equipped)

IMPORTANT: Install hardware with lock nuts and flat washers on the outside of cutter.

1. Install deflector using two (2) foot guards (See INSTALL FOOT GUARDS in this section) and provided bolts, flat washers, and lock nuts. Insert bolts and flat washer from inside out of rotary cutter.
2. Start with holes closest to center of machine and work towards outside edge of the rotary cutter, inserting bolts and flat washers.
3. For best results, stretch rubber towards outside edge of rotary cutter as lock nuts are tightened.

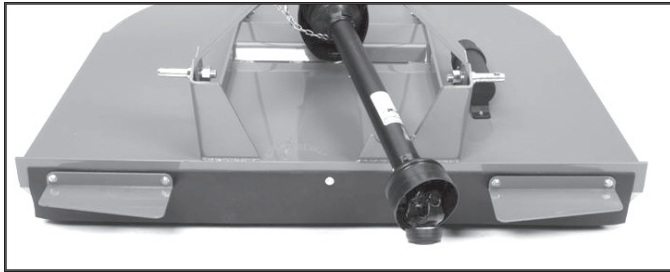

• Install Foot Guards (If Equipped)

NOTE: Foot guards are also used with rubber front safety shield.

IMPORTANT: Install hardware with lock nuts and flat washers on the outside of cutter.

1. Install guards on each side of machine with long leg toward center of cutter and fasten with the Two (2) bolts, flat washers and lock nuts provided per guard. Insert bolts and flat washer from inside out of rotary cutter. Tighten hardware to specifications in torque chart.



RC1072 Model



RC1048 & RC1060 Model

• Install Rear Deflector-Chains (If Equipped)

IMPORTANT: Install hardware with lock nuts and flat washers on the outside of cutter.

1. Install deflector using provided bolts, flat washers, and lock nuts. Insert bolt and flat washer from inside out of rotary cutter. Tighten hardware to specifications in torque chart.

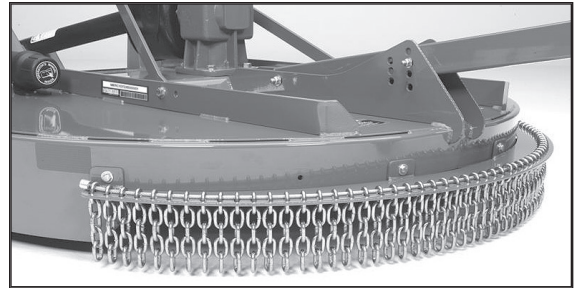

• Install Rear Deflector-Rubber (If Equipped)

IMPORTANT: Install hardware with lock nuts and flat washers on the outside of cutter.

1. Install deflector 3 metal bands and provided bolts, flat washers, and lock nuts. Insert bolt and flat washer from inside out of rotary cutter.
2. Start with holes closest to center of machine and work toward outside edge of the rotary cutter, inserting bolts and flat washers.
3. For best results, stretch rubber toward outside edge of rotary cutters as lock nuts are tightened. Tighten hardware to specifications in torque chart.
4. RC1072 only - Install bolts, and lock nuts in holes between the outside metal bands and the inside metal bands with bolt head and flat washer on inside of cutter and flat washer and lock nut on outside of cutter.

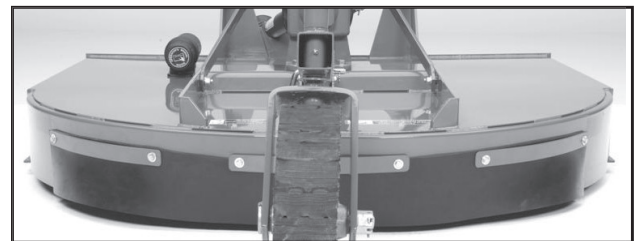

ASSEMBLY

Final Inspection and Adjustments

IMPORTANT: PTO driveline may be too long for some tractor models, causing tractor transaxle damage. Modify driveline if necessary.

Attach rotary cutter to tractor and check cutter-to-tractor driveline telescoping length clearance. (See CHECKING DRIVELINE/CUTTER CLEARANCE in Attaching section.)

IMPORTANT: Blade hardware **MUST** be checked after the first hour and every eight (8) hours thereafter.

Check blade hardware torque. Re-tighten hardware after one hour of operation and every eight (8) hours thereafter. (See MAINTENANCE BEFORE EACH USE in Lubrication and Maintenance section.)

MODIFY PTO DRIVELINE

• Modify PTO Driveline (If Necessary)

1. To adjust the length, hold the half-shafts next to each other in the shortest working position and mark them.

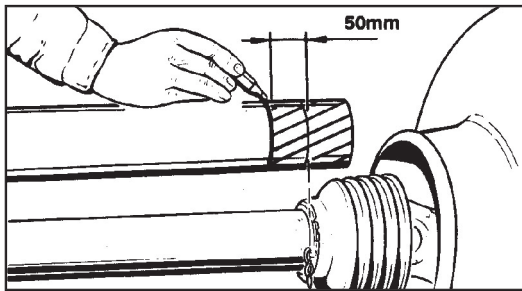

2. Shorten inner and outer guard tubes equally.

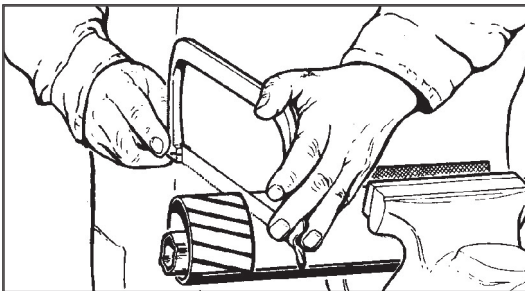

3. Shorten inner and outer sliding profiles by the same length as the guard tubes.

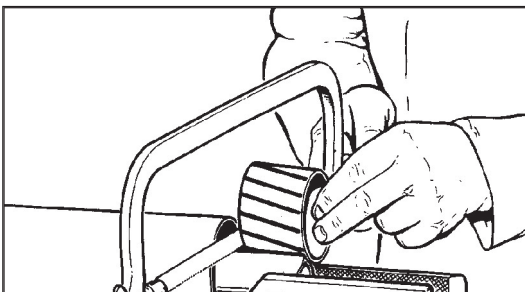

4. Round off all sharp edges and remove burrs. Grease sliding profiles. No other changes may be made to PTO drive shaft and guard.

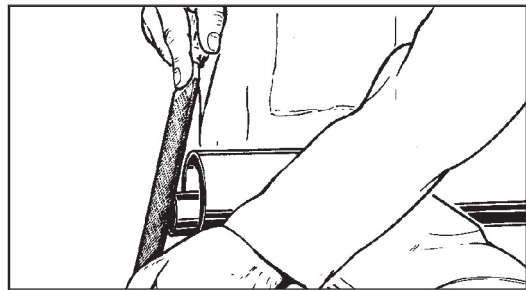

5. Chains must be fitted so as to allow sufficient articulation of the shaft in all working positions.

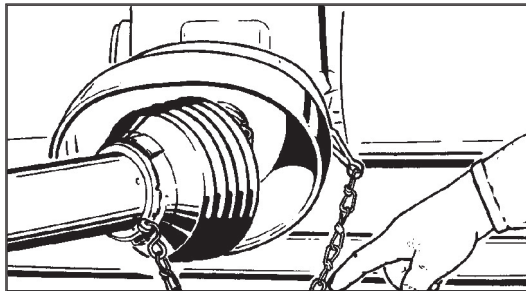

6. The PTO drive shaft must not be suspended from the chains!

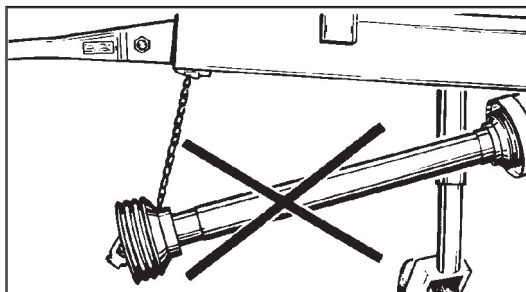

TORQUE SPECIFICATIONS

Proper torque for American fasteners used on manufactured implement.
Recommended Torque in Foot Pounds (Newton Meters).*

AMERICAN Bolt Head Markings



SAE Grade 2
(No Dashes)

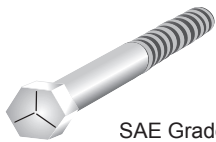

SAE Grade 5
(3 Dashes)

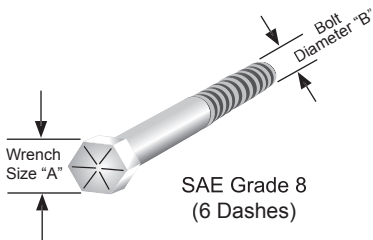

SAE Grade 8
(6 Dashes)

WRENCH SIZE (IN.) "A"	BOLT DIAMETER (IN.) "B" AND THREAD SIZE	SAE GRADE 2	SAE GRADE 5	SAE GRADE 8
7/16	1/4 -20 UNC	6 (7)	8 (11)	12 (16)
7/16	1/4 - 24 UNF	6 (8)	10 (13)	14 (18)
1/2	5/16 -18 UNC	11 (15)	17 (23)	25 (33)
1/2	5/16 - 24 UNF	13 (17)	19 (26)	27 (37)
9/16	3/8 - 16 UNC	20 (27)	31 (42)	44 (60)
9/16	3/8 -24 UNF	23 (31)	35 (47)	49 (66)
5/8	7/16 -14 UNC	32 (43)	49 (66)	70 (95)
5/8	7/16 - 20 UNF	36 (49)	55 (75)	78 (106)
3/4	1/2 - 13 UNC	49 (66)	76 (103)	106 (144)
3/4	1/2 - 20 UNF	55 (75)	85 (115)	120 (163)
7/8	9/16 -12 UNC	70 (95)	109 (148)	153 (207)
7/8	9/16 - 18 UNF	79 (107)	122 (165)	172 (233)
15/16	5/8 - 11 UNC	97 (131)	150 (203)	212 (287)
15/16	5/8 - 18 UNF	110 (149)	170 (230)	240 (325)
1-1/8	3/4 - 10 UNC	144(195)	266 (360)	376 (509)
1-1/8	3/4 - 16 UNF	192 (260)	297 (406)	420 (569)
1-5/16	7/8 - 9 UNC	166 (225)	430 (583)	606 (821)
1-5/16	7/8 - 14 UNF	184 (249)	474 (642)	668 (905)
1-1/2	1-8 UNC	250 (339)	644 (873)	909 (1232)
1-1/2	1 - 12 UNF	274 (371)	705 (955)	995 (1348)
1-1/2	1-14 UNF	280 (379)	721 (977)	1019 (1381)
1-11/16	1-1/8 - 7 UNC	354 (480)	795 (1077)	1288 (1745)
1-11/16	1-1/8 -12 UNF	397 (538)	890 (1206)	1444 (1957)
1-7/8	1-1/4 - 7 UNC	500 (678)	1120 (1518)	1817 (2462)
1-7/8	1-1/4 - 12 UNF	553 (749)	1241 (1682)	2013 (2728)
2-1/16	1-3/8 - 6 UNC	655 (887)	1470 (1992)	2382 (3228)
2-1/16	1-3/8 -12 UNF	746 (1011)	1672 (2266)	2712 (3675)
2-1/4	1-1/2 - 6 UNC	870 (1179)	1950 (2642)	3161 (4283)
2-1/4	1-1/2 - 12 UNF	979 (1327)	2194 (2973)	3557 (4820)

Proper torque for metric fasteners used on manufacturer implement.
Recommended Torque in Foot Pounds (Newton Meters).*

METRIC

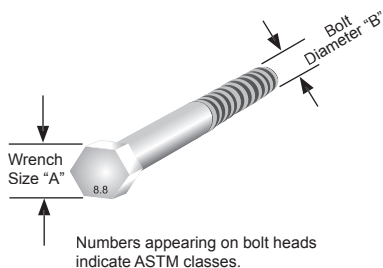

Numbers appearing on bolt heads indicate ASTM classes.

WRENCH SIZE (mm) "A"	BOLT DIA. (mm) "B"	ASTM 4.6	ASTM 8.8	ASTM 9.8	ASTM 10.9
8	5	1.8 (2.4)		5.1 (6.9)	6.5 (8.8)
10	6	3 (4)		8.7 (12)	11.1 (15)
13	8	7.3 (10)		21.1 (29)	27 (37)
16	10	14.5 (20)		42 (57)	53 (72)
18	12	25 (34)	74 (100)	73 (99)	93 (126)
21	14	40 (54)	118 (160)	116 (157)	148 (201)
24	16	62 (84)	167 (226)	181 (245)	230 (312)
30	20	122 (165)	325 (440)		449 (608)
33	22		443 (600)		611 (828)
36	24	211 (286)	563 (763)		778 (1054)
41	27		821 (1112)		138(1542)
46	30	418 (566)	1119 (1516)		1547(2096)

*Use 75% of the specified torque value for plated fasteners. Use 85% of the specified torque values for lubricated fasteners.

TROUBLESHOOTING GUIDE

Problem	Possible Cause	Possible Remedy
Leaves a streak of uncut or partially cut grass.	<ol style="list-style-type: none"> 1. Rotary cutter not level, side to side. 2. Blade dull or bent. 3. Blades unable to cut that part of grass pressed by path of tractor tires. 4. Possible build up of material under rotary cutter. 	<p>Level 3-pt hitch linkage on tractor.</p> <p>Sharpen or replace blades.</p> <p>Slow ground speed of tractor but keep engine running at full PTO rpm. Cutting lower will help.</p> <p>Clean rotary cutter.</p>
Blade cuts grass lower in center of swath than at the edge.	<ol style="list-style-type: none"> 1. Height of rotary cutter lower at rear or at front. 	<p>Adjust rotary cutter height and altitude so that rotary cutter rear & front are with 1/2" of same height.</p>
Material discharges from cutter unevenly, or discharges clumps of grass.	<ol style="list-style-type: none"> 1. Grass or brush may be too high or thick. 2. Grass wet. 	<p>Reduce ground speed but maintain 540 rpm at tractor PTO, or make two passes over material. Raise rotary cutter for the first pass and lower for the second pass, preferably cutting 90° to the first pass. Raise rear of rotary cutter high enough to permit material to discharge.</p> <p>Allow grass to dry before mowing. Slow ground speed of tractor but keep engine running at full PTO rpm. Cutting lower will help.</p>
Gearbox overheating.	<ol style="list-style-type: none"> 1. Low on lubricant. 2. Improper lubricant type. 3. Excessive trash build up around gearbox. 	<p>Fill to proper level.</p> <p>Replace with proper lubricant.</p> <p>Remove trash.</p>
Rotary cutter will not cut. Rotary cutter will not cut all the time. (slip clutch only)	<ol style="list-style-type: none"> 1. Shear bolt sheared 2. Slip clutch slipping. 	<p>Install new shear bolt.</p> <p>Adjust slip clutch according to guidelines on page 22.</p>
Excessive vibration.	<ol style="list-style-type: none"> 1. Possible build up of material on blade 2. Blades locked into position. 3. Check for even wear on each blade tip. 4. Broken blade. 5. New blade or bolts not matched with worn blade or bolts. 	<p>Clean blade pan.</p> <p>Free blades so they swing free.</p> <p>Weigh each blade. Weight should be within 1 oz. Always replace both blades.</p> <p>Replace blades, in set.</p> <p>Replace blades or bolts in sets.</p>
Gearbox noisy.	<ol style="list-style-type: none"> 1. Low oil in gearbox. 	<p>Check oil level. Add oil.</p>

PARTS

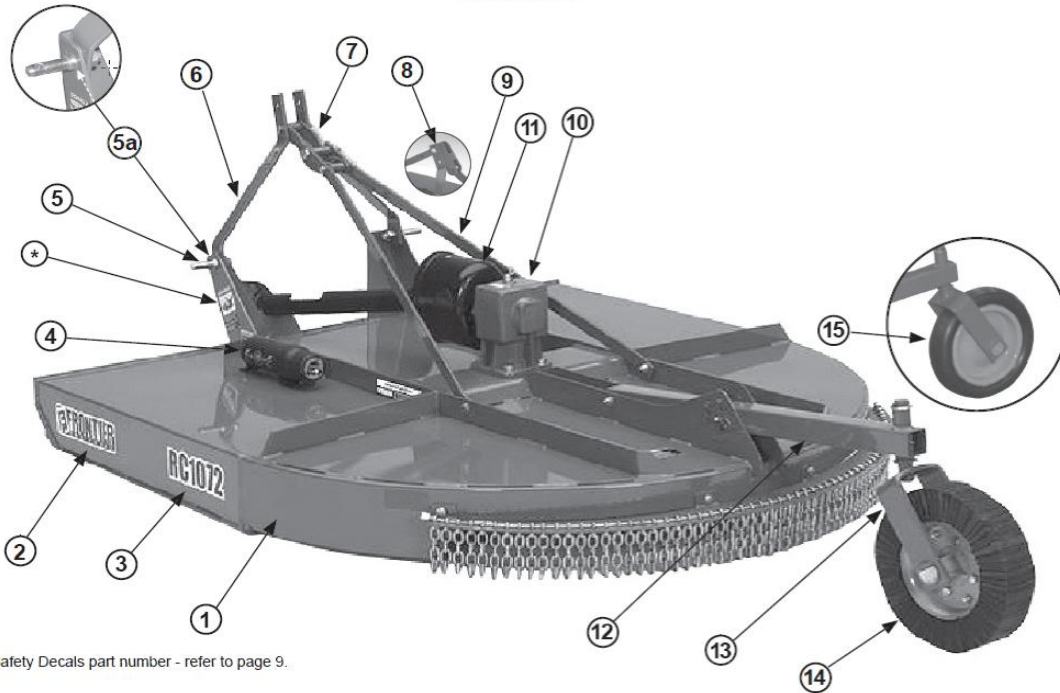

* For Safety Decals part number - refer to page 9.

Parts Overall View

Item Number	Ship Qty.	Part Number	Description
1	1	5TIFC711287	Deck Assembly - RC1048 (Includes gearbox, blade pan, blades, and hitch. Does not include tailwheel assembly, driveline, or front and rear deflectors.)
1	1	5TIFC711286	Deck Assembly - RC1060 (Includes gearbox, blade pan, blades, and hitch. Does not include tailwheel assembly, driveline, or front and rear deflectors.)
1	1	5TIFC711288	Deck Assembly - RC1072 (Includes gearbox, blade pan, blades, and hitch. Does not include tailwheel assembly, driveline, or front and rear deflectors.)
2	1	TIFC711172	Frontier Logo Decal
3	1	ME100561	Model Number Decal (RC1048)
3	1	ME100562	Model Number Decal (RC1060)
3	1	ME100563	Model Number Decal (RC1072)
4	1	TIFC711111	Manual Tube
5	1	TIFC711112	Lift Pin, Cat 1
5a	1	TIFC711191	Lift Pin, Bushing
6	1	ME300326	Top Link Mount
7	1	ME300277	iMatch Pivot Link Kit
8	1	ME300288	Non - iMatch Link Clevis
9	1	ME300283	Lift Strap RC1048 and RC1060
9	1	ME300284	Lift Strap RC1072
10	1	TIFC711114	RC1048 Gearbox 45 hp
10	1	TIFC711115	RC1060 Gearbox 65 hp
10	1	TIFC711116	RC1072 Gearbox 65 hp
11	1	TIFC711118	Slip Clutch Shield Cone
12	1	TIFC711145	Tailwheel Tube Assembly for RC1048,RC1060 & RC1072
13	1	TIFC711210	Tailwheel Fork with Roll Pin
14	1	TIFC711211	Laminated Tailwheel
15	1	TIFC711212	Solid Rubber Tire Tailwheel

34 PARTS

PARTS

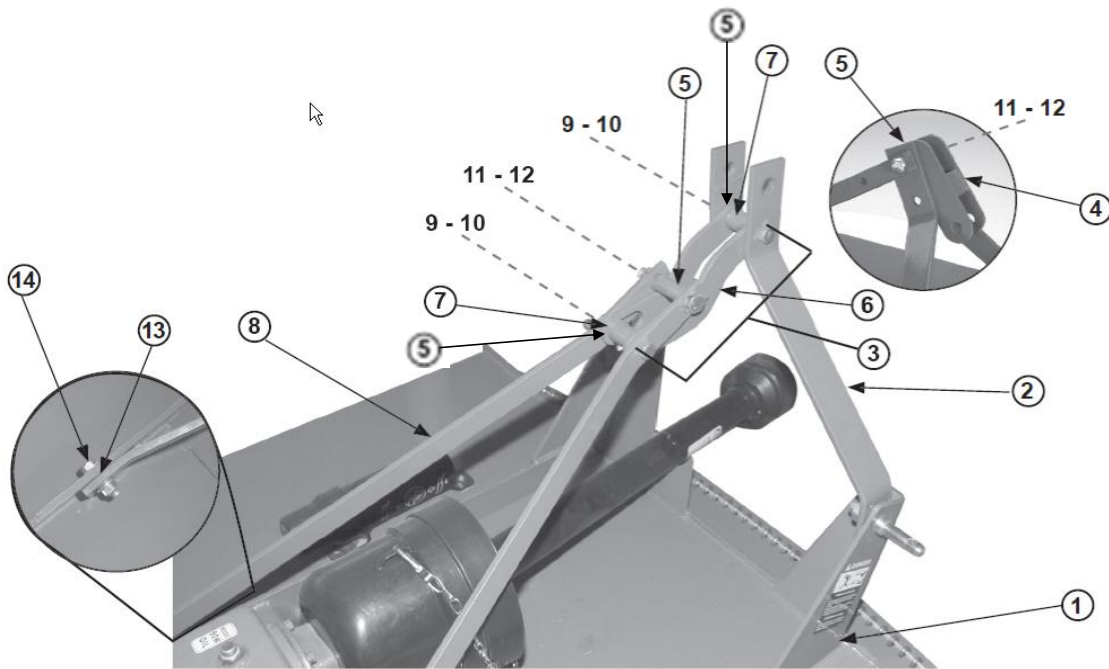

Hitch Assembly

Item Number	Ship Qty.	Part number	Description
1	NA	NA	Hitch Mount Lug
2	1	ME300326	Top Link Mount
3	1	ME300277	iMatch Pivot Link Kit
4	1	ME300288	Non- iMatch Link Clevis
5	1	ME300282	Hitch Pivot Bushing
6	1	ME300280	iMatch Pivot Link
7	1	ME300279	iMatch Mount Bushing
8	1	ME300283	Lift Strap RC1048 and RC1060
8	1	ME300284	Lift Strap RC1072
9-10	1	TIFC711160	iMatch Hitch Pivot Bolt and Lock Nut (5/8" x 4 1/2" Hex Bolt Grade 5 & Lock Nut) (Replaces: ME100150)
11	1	ME100102	Hitch Pivot Bolt (3/4" x 5" Hex Bolt Grade 5) (Replaces: ME100170)
12	1	ME100112	Hitch Pivot Lock Nut (3/4" Lock Nut)
13	1	ME300285	Lift Strap Bushing
14	4	TIFC711190	Bolt 1/2 x 1-3/4" and Lock Nut

PARTS

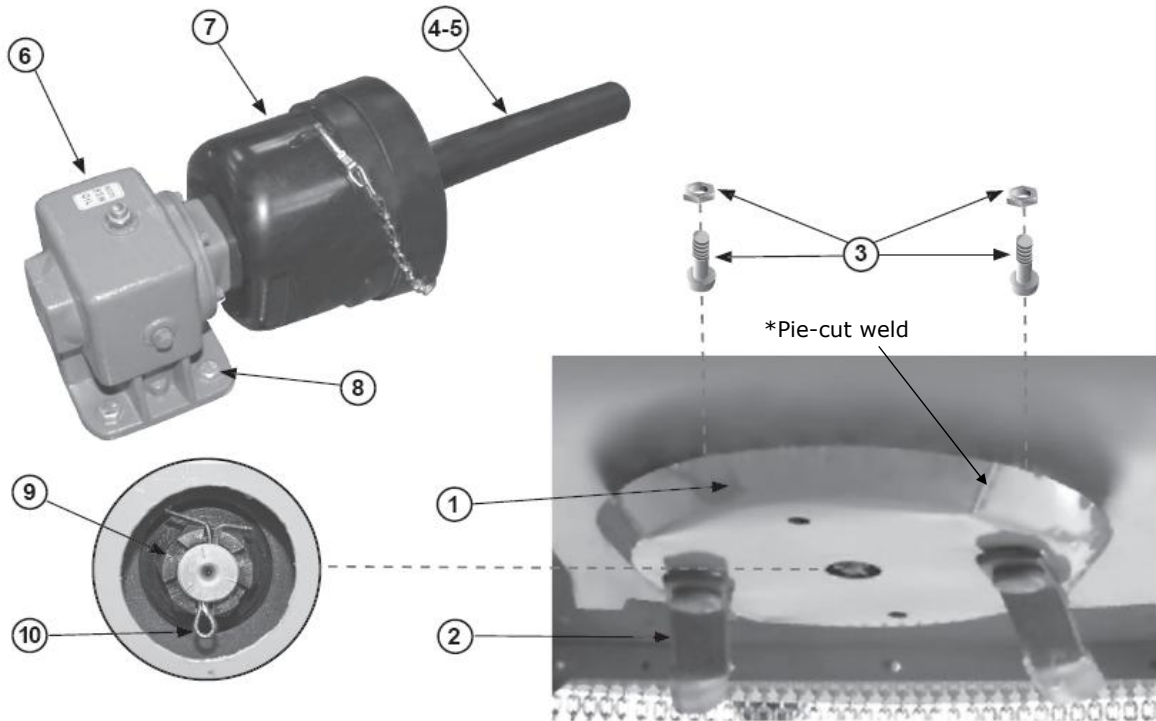

Gearbox and Blade Pan Assembly				
Item Number	Ship Qty.	Part Number	Description	
1	1 Set	ME400100	Blade Pan RC1048 Assembly (Blade Pan, Bolts, Blades) (Stamped pan)	
1	1 Set	ME400101	Blade Pan RC1060 Assembly (Blade Pan, Bolts, Blades) (Stamped pan)	
1	1 Set	ME400102	Blade Pan RC1072 Assembly (Blade Pan, Bolts, Blades) (Stamped pan)	
2	1 Set	ME300125	Blade Set (2 Blades) RC1048 (Pie-cut weld blade pan)*	
2	1 Set	TIFC711121	Blade Set (2 Blades) RC1048 (Stamped blade pan - No pie-cut welds)*	
2	1 Set	ME300126	Blade Set (2 Blades) RC1060 and RC1072 (Pie-cut weld blade pan.)*	
2	1 Set	TIFC711122	Blade Set (2 Blades) RC1060 (Stamped Blade Pan - No pie-cut welds.)*	
2	1 Set	TIFC711123	Blade Set (2 Blades) RC1072 (Stamped Blade Pan - No pie-cut welds.)*	
3	1 Set	ME300227	Hex Key Blade Bolt Set (2 blade bolts and locknuts) (Pie-cut weld blade pan)*	
3	1 Set	TIFC711124	Tab Key Blade Bolt Set (2 blade bolts and locknuts) Stamped Blade Pan (No pie-cut welds)*	
4	1	TIFC711125	Complete PTO Shaft/Driveline (Shear Pin) RC1048	
4	1	TIFC711126	Complete PTO Shaft/Driveline (Shear Pin) RC1060 and RC1072	
5	1	TIFC711127	Complete PTO Shaft/Driveline (Slip Clutch) RC1048	
5	1	TIFC711128	Complete PTO Shaft/Driveline (Slip Clutch) RC1060 and RC1072	
6	1	TIFC711114	Gearbox 45 hp - RC1048	
6	1	TIFC711115	RC1060 Gearbox 65 hp	
6	1	TIFC711116	RC1072 Gearbox 65 hp	
7	1	TIFC711118	Slip Clutch Shield Cone w/ Hardware	
8	4	TIFC711192	Gearbox Mounting Bolts w/ Lock Nuts Kit (4 bolts and nuts)	
9-10	1	TIFC711194	Castle Nut w/ Cotter Pin (Gearbox output shaft)	

36 Parts

PARTS

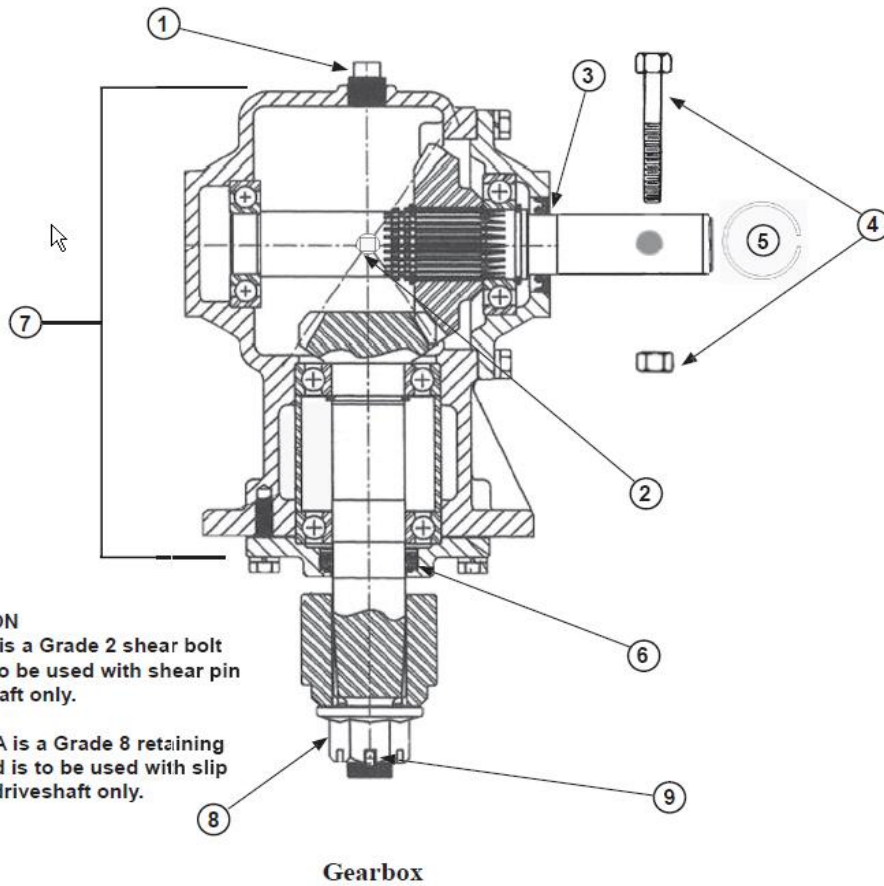

Item Number	Ship Qty.	Part number	Description
1	1	TIFC711155	Breather Fill Plug
2	1	TIFC711197	Oil Level Plug 1/2"
3	1	5TIFC711290	Seal, Input Shaft
4	10	TIFC711156	Shear Bolt and Lock Nut Gr 2
4A	5	TIFC711193	Retaining Bolt and Lock Nut (Slip Clutch Driveshaft only - Grade 8)
5	5	TIFC711157	Snap Ring, Input Shaft
6	1	5TIFC711291	Seal, Output Shaft
7	1	TIFC711114	Gearbox 45 hp - RC1048
7	1	TIFC711115	RC1060 Gearbox 65 hp
7	1	TIFC711116	RC1072 Gearbox 65 hp
8-9	1	TIFC711194	Castle Nut w/ Cotter Pin (Gearbox output shaft)

PARTS

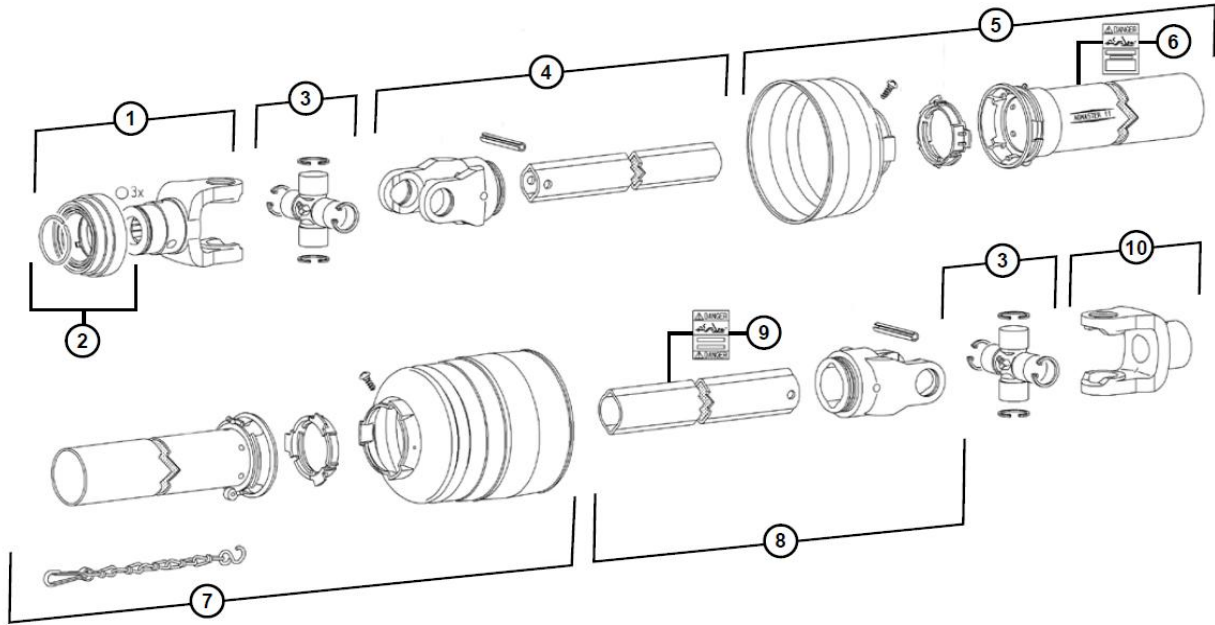

RC10 Series Shear Bolt PTO Shaft				
Item Number	Qty.	Qty. Shipped	Part Number	Description
1	1	1	TIFC711176	Yoke 1 3/8-6 SPL
2	1	1	TIFC711178	Collar Kit
3	2	2	TIFC711177	Cross and Bearing Kit
4	1	1	TIFC711131	Inboard Yoke Assembly RC1048
4	1	1	TIFC711132	Inboard Yoke Assembly RC1060, RC1072
5	1	1	TIFC711133	Out Shield Assembly RC1048
5	1	1	TIFC711134	Out Shield Assembly RC1060, RC1072
6	1	1	TIFC711179	Decal Out In
7	1	1	TIFC711135	Inn Shield Assembly RC1048 For Shear Pin
7	1	1	TIFC711136	Inn Shield Assembly RC1060, RC1072 For Shear Pin
8	1	1	TIFC711137	Outer Profile Inboard Yoke Assembly RC1048
8	1	1	TIFC711138	Outer Profile Inboard Yoke Assembly RC1060, RC1072
9	1	1	TIFC711180	Decal Inn In
10	1	1	TIFC711181	Yoke 1 3/8" RB, 0.531 DT
NA	1	1	TIFC711125	Complete PTO Shaft/Driveline (Shear Pin) RC1048
NA	1	1	TIFC711126	Complete PTO Shaft/Driveline (Shear Pin) RC1060 and RC1072

38 Parts

PARTS

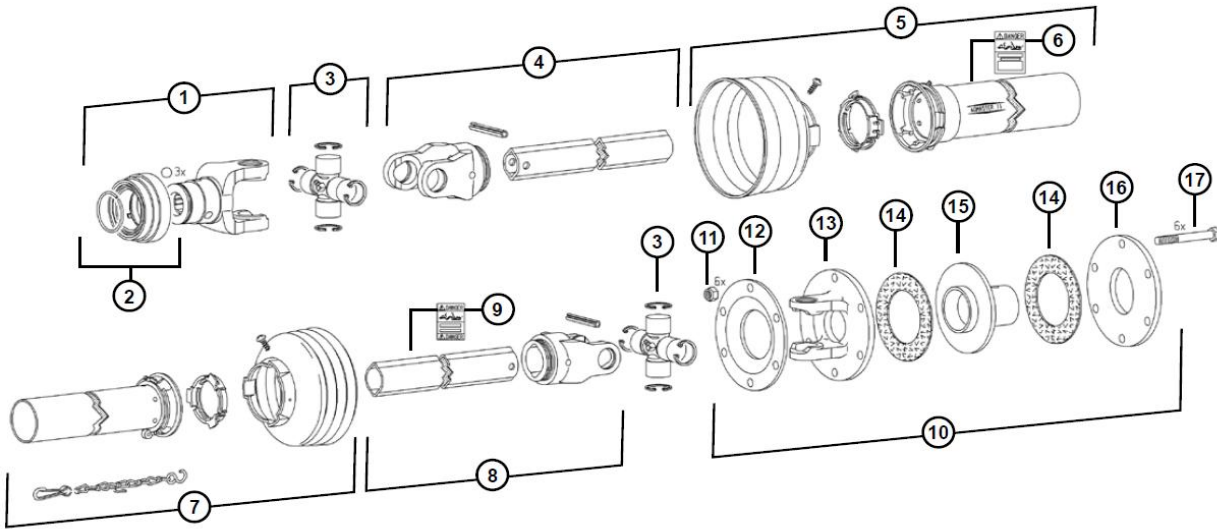

RC10 Series Slip Clutch PTO Shaft				
Item Number	Qty.	Qty. Shipped	Part Number	Description
1	1	1	TIFC711176	Yoke 1 3/8-6 SPL
2	1	1	TIFC711178	Collar Kit
3	2	2	TIFC711177	Cross and Bearing Kit
4	1	1	TIFC711131	Inboard Yoke Assembly RC1048
4	1	1	TIFC711132	Inboard Yoke Assembly RC1060, RC1072
5	1	1	TIFC711133	Out Shield Assembly RC1048
5	1	1	TIFC711134	Out Shield Assembly RC1060, RC1072
6	1	1	TIFC711179	Decal Out In
7	1	1	TIFC711166	Inn Shield Assy RC1048 for Slip Clutch
7	1	1	TIFC711168	Inn Shield Assy RC1060, RC1072 for Slip Clutch
8	1	1	TIFC711137	Outer Profile Inboard Yoke Assembly RC1048
8	1	1	TIFC711138	Outer Profile Inboard Yoke Assembly RC1060, RC1072
9	1	1	TIFC711180	Decal Inn In
10	1	1	TIFC711188	Friction Clutch Assembly
11	6	6	TIFC711182	Lock Nut
12	1	1	TIFC711183	Belleville Spring
13	1	1	TIFC711184	Flange Yoke
14	2	2	TIFC711167	Friction Disc
15	1	1	TIFC711185	Hub
16	1	1	TIFC711186	Thrust Plate
17	6	6	TIFC711187	Bolt
NA	1	1	TIFC711127	Complete PTO Shaft/Driveline (Slip Clutch) RC1048
NA	1	1	TIFC711128	Complete PTO Shaft/Driveline (Slip Clutch) RC1060 and RC1072

PARTS

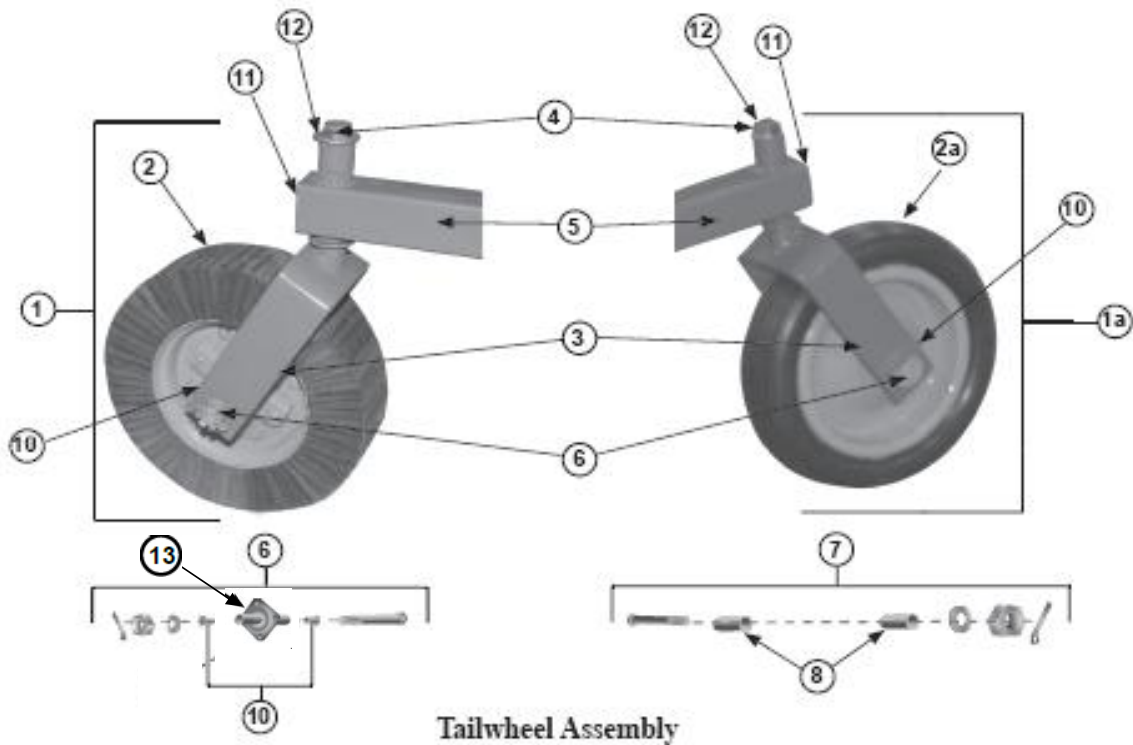

Item Number	Ship Qty.	Part Number	Description
1	1	TIFC711117	Laminated Tailwheel Assembly - Complete
1a	1	TIFC711119	Solid Rubber Tailwheel Assembly - Complete
2	1	TIFC711211	Tailwheel - Laminated Tire
2a	1	TIFC711212	Tailwheel - Solid Rubber Tire
3	1	TIFC711210	Tailwheel Fork with Roll Pin
4	5	TIFC711154	Roll Pin (Tailwheel Fork)
5	1	TIFC711145	Tailwheel Tube for RC1048, RC1060 and RC1072
6	1	TIFC711196	Axle Bolt Kit Laminated Tire (does not include hub)
7	1	TIFC711198	Axle Bolt Kit Solid Rubber Tire
8	2	ME300242	Bushing (Tailwheel - Solid Rubber Tire)
10	2	TIFC711213	Bushing (Tailwheel - Laminated Tire)
11	5	TIFC711152	Grease Zerk on Tube
12	5	TIFC711147	1 1/4" Flat Washer
13	1	5TIFC711296	Tailwheel hub for laminated tire
NA	5	TIFC711195	Grease Zerk On Laminated Tire

40 Parts

PARTS

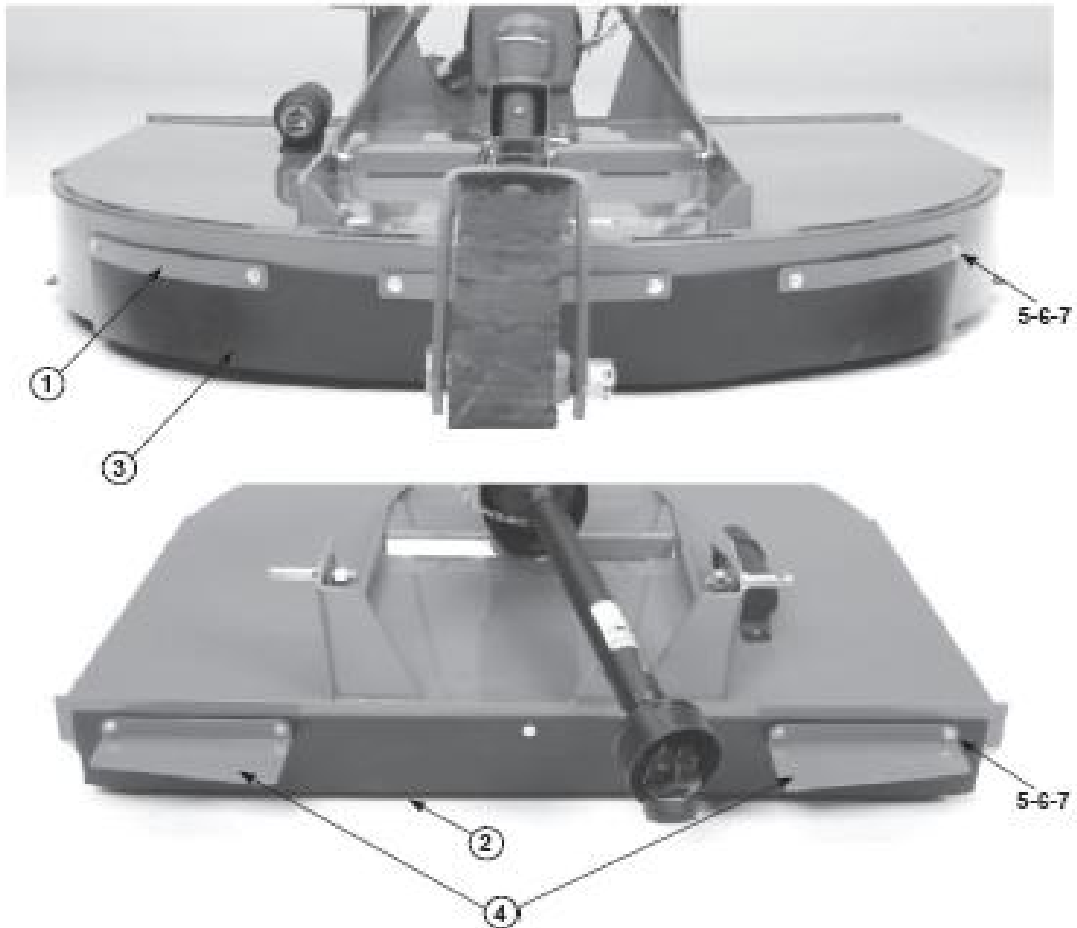

Rubber Belt Deflector and Foot Guard Assembly

Item Number	Ship Qty.	Description	RC1048	RC1060	RC1072
			Part Number	Part Number	Part Number
1	1	Rear Rubber Deflector Strap Kit (3 Metal Straps w/ Hardware)	ME300243	ME300243	ME300243
2	1	Front Rubber Deflector	TIFC711169	TIFC711170	TIFC711171
3	1	Rear Rubber Deflector	TIFC711163 (metal deflector less hardware)	TIFC711164 (metal deflector less hardware)	TIFC711165 (metal deflector less hardware)
4	1	Foot Guard w/ Hardware (pair)	ME300212	ME300212	ME300212
5	1	5/16" x 1 1/2" Bolt Gr 5	ME100202	ME100202	ME100202
6	1	5/16" Flat Washer	ME100142	ME100142	ME100142
7	1	5/16" Lock Nut	ME100135	ME100135	ME100135

PARTS

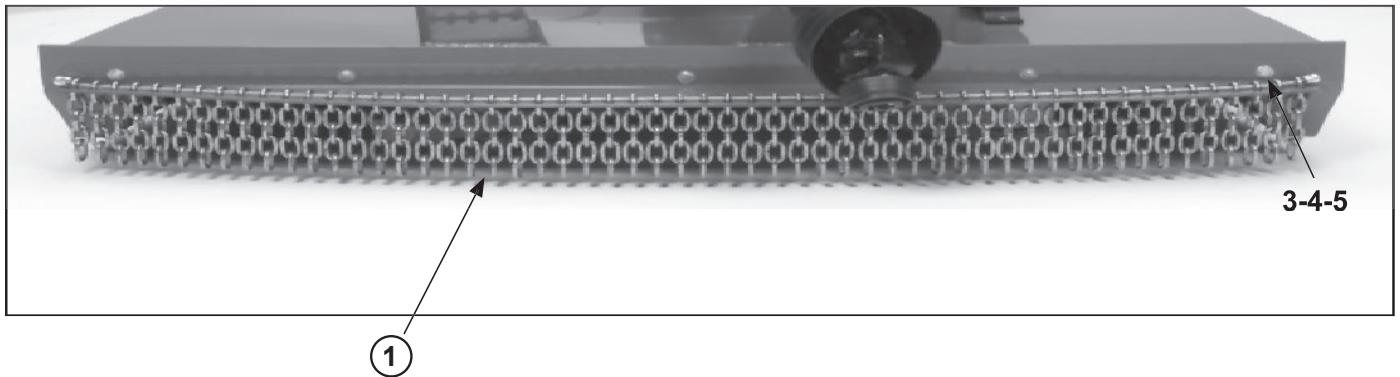
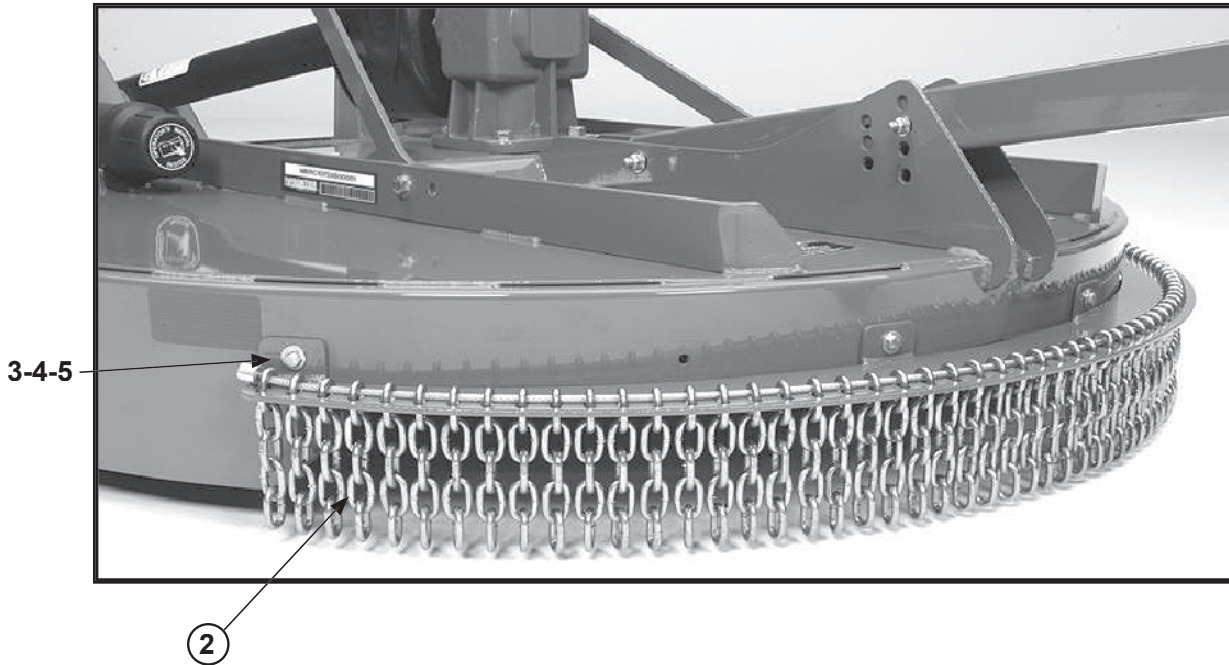

Chain Deflector Assembly

Item Number	Qty.	Description	Part Number		
			RC1048	RC1060	RC1072
1	1	Front Chain Deflector Kit	ME300219	ME300221	ME300223
2	1	Rear Chain Deflector Kit	ME300220	ME300222	ME300224
3	1	5/16" x 1 1/2" Bolt Gr 5	ME100202	ME100202	ME100202
4	2	5/16" Flat Washer	ME100142	ME100142	ME100142
5	1	5/16" Lock Nut	ME100135	ME100135	ME100135

42 Parts

**PART NUMBER
ME300309**

